



LEEDS
BECKETT
UNIVERSITY

Citation:

Alzetto, F and Farmer, DJ and Fitton, R and Hughes, T and Swan, W (2018) Comparison of whole house heat loss test methods under controlled conditions in six distinct retrofit scenarios. *Energy and Buildings*, 168. pp. 35-41. ISSN 0378-7788 DOI: <https://doi.org/10.1016/j.enbuild.2018.03.024>

Link to Leeds Beckett Repository record:

<https://eprints.leedsbeckett.ac.uk/id/eprint/4885/>

Document Version:

Article (Accepted Version)

The aim of the Leeds Beckett Repository is to provide open access to our research, as required by funder policies and permitted by publishers and copyright law.

The Leeds Beckett repository holds a wide range of publications, each of which has been checked for copyright and the relevant embargo period has been applied by the Research Services team.

We operate on a standard take-down policy. If you are the author or publisher of an output and you would like it removed from the repository, please [contact us](#) and we will investigate on a case-by-case basis.

Each thesis in the repository has been cleared where necessary by the author for third party copyright. If you would like a thesis to be removed from the repository or believe there is an issue with copyright, please contact us on openaccess@leedsbeckett.ac.uk and we will investigate on a case-by-case basis.

Comparison of whole house heat loss test methods under controlled conditions in six distinct retrofit scenarios

Authors: Florent Alzetto^a, David Farmer^b, Richard Fitton^c, Tara Hughes^c, Will Swan^c

^aSaint-Gobain Recherche, 39 quai Lucien Lefranc, 93303, Aubervilliers Cedex, France

^bCentre for the Built Environment, Leeds Sustainability Institute, Leeds Beckett University, BPA223 Broadcasting Place, Woodhouse Lane, Leeds, LS2 9EN, UK

^cEnergy House Test Facility, College of Science & Technology, G16a, Cockcroft Building, University of Salford, Salford, M5 4WT, UK

Corresponding author:

Florent Alzetto

Saint-Gobain Recherche

39 quai Lucien Lefranc

93303, Aubervilliers Cedex, France

e-mail address: Florent.Alzetto@saint-gobain.com

Abstract

The accurate assessment of buildings to assess their performance across a range of parameters is an essential part of understanding both new and retrofit buildings. The growing understanding of the performance gap in terms of its assessment and characterisation relies on effective methods of analysis. Here, we evaluate an experimental whole house method, known as QUB. As with many whole building approaches the method establishes heat loss through transmission and ventilation losses.

This study compares QUB against an alternative, established, whole house test known as coheating. It was applied in a whole house test facility under controlled conditions. The test property, a solid wall pre-1919 UK archetype, was retrofit using a set of commercially available products and then the retrofit was removed in stages. At each of these stages a QUB test, which commonly takes one night, and coheating test, which can take few weeks, were applied. The objective of the study was to provide a comparison between the new method and more established method in terms of accuracy.

The two methods showed close agreement in terms of results, suggesting that the quicker test has great potential as a more practical and economic test. There were higher levels of uncertainty with the QUB method due to shorter measurement periods. The lack of full boundary conditions within the test facility should be considered a limitation in applying the findings directly to the field. However, this study indicates the potential for QUB in validating performance, warranting further investigation.

Keywords: Coheating, Building Thermal Performance, Performance gap, thermal performance methods, HLC, QUB, retrofit.

1) Introduction

The *performance gap* describes the difference between the predicted and actual thermal performance of buildings. Whole building heat loss tests show that dwellings can experience 60 percent or greater heat loss than designed [1,2]. This can be attributed to a wide variety of reasons ranging from the design and construction of a building to its use by occupants [3].

The final energy consumption in the domestic sector is 27% of total UK final energy use [4]. This has major implications for policy, such as energy efficiency and fuel poverty targets. An understanding of the actual performance of buildings, taking into account the identified performance gap issues, is essential if we are to deliver policy targets and positive outcomes for occupants.

The drivers for energy consumption are manifold. Consumption of energy use in the EU is largely driven by demand for space heating, with an average figure across the EU member states of 68 % of final energy consumption in the household sector [5]. Interactions between the fabric, systems, controls and occupants form complex relationships to determine overall energy use.

The performance gap is compounded by the difficulties of monitoring domestic properties in the field, with many tests proving intrusive and difficult to implement, particularly in occupied properties [6].

Fabric is a major contributor to the overall efficiency of a property when considering heating loads [7]. In retrofit, where existing buildings are raised to higher standards of energy efficiency, in particular, a fabric first approach is recommended [8]. Understanding the building fabric can be approached through qualitative methods such as thermography, or quantitative methods, such as in situ U-values measurements. However, there are also a number of approaches that are used to investigate the whole building performance.

The heat loss from an entire building envelope can be quantified using the Heat Loss Coefficient (HLC). The HLC is the rate of heat loss in Watts from the entire thermal envelope of a building per Kelvin of temperature differential between the internal and external environments (ΔT) and is expressed in units of W/K. The HLC is an aggregate of the total fabric transmission and background ventilation heat losses from the thermal envelope. A non-exhaustive list of available methodologies is provided in table 1.

Method	Length of test period	Description
Coheating [9]	7-21 days	Quasi steady state test using electrical heaters and fans to create a stable internal temperature whilst outdoor conditions remain variable. Power input to maintain an elevated temperature is used to calculate a global heat loss figure for the building.
QUB [10]	2 days	A dynamic test using electrical heating to increase the temperature in the building and then allow to cool over 2 periods after sunset. Power input is monitored along with internal and external conditions to calculate a global heat loss figure.
P-STAR [27]	3 days	The methodology is like Coheating methodology with the exception that three internal conditions are created, one heating period (16 hours), one cooling down period (16 hours) and finally a heating period. Power input, internal and external environmental conditions are measured during these periods. Using this dynamic pattern identification can be made of the HLC of the building alongside the thermal mass levels.
PRISM [28]	1 Year	Meter readings are taken over a year long period, the heating fuels for the building; this data is then adjusted using a degree day methodology/weather normalisation. From here a W/K figure can be calculated alongside an annual prediction of heating fuel consumption, given typical weather conditions.
ISABELE [19]	15 days maximum	Following a short (1/2 day) period of no heating, a controlled power is injected into the building to meet a certain increase in the temperature to a given set point (minimum of 2 days). Then a final stage of temperature decrease, with the heating switched off is recorded. The test records power input, internal and external conditions which allow a global heat loss figure to be calculated. The test can last between 5-15 days depending on the fabric of the building.

Table 1: List of existing methods to estimate the HLC

In this paper we compare two methods of estimating the HLC of a dwelling in a unique testing facility at the University of Salford. This facility allowed the HLC to be estimated by both methods at six stages of retrofit under exactly the same conditions. The first method is one of the current leading approaches, the coheating test, which can take 1-3 weeks [9]. The second method, which is currently under development, is the QUB test, which takes 1-2 days [10]. This has the potential to take the HLC methodology from a research focused tool to wider practical applications. We first start by describing the test house and then the different retrofit stages performed. We continue by presenting both coheating and QUB methodologies. Finally we compare and discuss the results obtained.

2) The Energy House

The Salford Energy House is a full scale pre-1919 solid-wall Victorian end-terrace house constructed inside an environmentally controlled chamber at the University of Salford [22]. The construction of the Salford Energy House Test Facility was achieved by using reclaimed materials and methods of the time. An adjacent house is also present so that the effects of a neighbouring property can be explored during experiments. A picture of this environment is shown in figure 1.



Figure 1: The Salford Energy House within its environmental chamber

The environmental chamber is a large reinforced concrete structure. The dimensions are 11.1 m wide, 9.3 m deep and 7.4 m high. This gives a chamber volume of 763 m³. The chamber walls are insulated with 100 mm PIR foam insulation to the walls and ceiling and 35mm expanded polystyrene insulation to the floor element (reinforced concrete slab on short bored piles). This helps to isolate the chamber from external influences such as wind, rain and solar gain. The chamber has the ability to maintain a constant temperature between the range -12°C and +30°C with an accuracy of +/-0.5°C at a 5°C setpoint. The chamber is cooled by an air handling unit that is supplied with cooling by 4 No. condenser units, with a total of 60 kW of cooling (15 kW per unit). This is supplied to the chamber via a ducted HVAC system. This system reacts to the heat load of the house in the chamber and maintains a setpoint of $\pm 0.5^{\circ}\text{C}$.

The Energy House Baseline case had the following construction:

- Solid brick walls 225.5 mm thick arranged in English bond (with every fifth course being a header row), with 9 mm mortar joints 12.5 mm hard wall plaster to inside face of wall with 2 mm skim as finishing coat. Magnolia paint to internal face of wall.
- The house is built off a reinforced concrete raft with no insulation added. A 200 mm gap exists between the house and this raft; this forms a ventilated floorspace and allows for a constant airflow beneath the house. The floor is

suspended on 200 mm timbers and is finished off with 22 mm floor boards (non-interlocking and non-sealed).

- The windows are double glazed units of a type found circa 2000. The doors are UPVC of amid range type, in terms of thermal performance.
- The roof is a timber rafter and purlin roof with 100 mm insulation at the time of the initial tests. A layer of mineral wool insulation. There is a small amount of eaves ventilation, sarking felt is installed.
- The party wall is a solid wall construction to match the external walls, and remained unplastered on the neighbouring side.

The construction of the neighbouring building is as follows:

- This building has a layer (60 mm) of closed cell foil backed insulation, to the external facing walls only, and not the party wall.
- The external facing walls are solid brick as above.
- The gable of this building is concrete block (2 skins of 100 mm with a 20 mm air gap).
- The loft has 200 mm of insulation.
- The doors are single skinned timber panel doors; the rear door is half glazed with single glazing.
- The floors are constructed in the same manner as the other building.

In order to compare both methodologies in few cases, five retrofits have been performed and measurements using both methodologies have been done at each stage. In the next section we describe the detail of the construction work.

3) Retrofit programme

Retrofit, or sustainable retrofit, can be defined as improvements made to the fabric, systems or controls of a property to specifically improve the energy performance of a building [23,24]. Retrofit is a response to reducing energy consumption in the built environment, considering that some 60-80% of buildings standing in 2050 have already been built. Retrofit is as subject to performance gap issues as new buildings [25]. In this study the retrofit was performed in five stages [29]. A summary of these stages is presented in Table 2.

Test stage	Condition of thermal element at each test phase			
	External wall	Roof	Glazing	Floor
Full retrofit	Hybrid solid wall insulation system 90 mm EPS EWI to gable and rear walls	270 mm mineral wool	A+++ glazing, argon fill, low e coating	200 mm mineral wool & membrane
Full retrofit (no floor insulation)				80 mm PIR IWI to front wall
Solid wall insulation	Uninsulated (solid wall)	270 mm mineral wool	1980s style double glazing units	
Glazing				100 mm mineral wool
Loft	270 mm mineral wool	1980s style double glazing units		
Baseline (original)			100 mm mineral wool	

Table 2: House configuration at each test stage (shading represents presence of a retrofit measure)

The thermal upgrade measures that were applied to the test house during the test programme summarized in table 2 are detailed below:

- Internal Wall Insulation (IWI) on the front wall: A thermal laminate board “British Gypsum ThermaLine” comprising 80 mm PIR rigid insulation board ($\lambda = 0.022$ W/mK) with vapour control barriers bonded to 12.5 mm Gyproc WallBoard formed the main insulating layer of the IWI system.
- External Wall Insulation (EWI) on the gable and rear walls: Weber Therm EWI system comprising 90 mm EPS boards ($\lambda = 0.037$ W/mK) were mechanically fixed to the external walls. A glass fabric mesh was applied over the first render coat then a render coat finish.
- Suspended timber floor insulation: 200 mm Isover Renovation Roll Thermal mineral wool insulation quilt ($\lambda = 0.035$ W/mK) suspended by Insumate tray system between floor joists. An Isover Vario KM Duplex UV nylon based microporous airtightness and moisture membrane installed below the floorboards with overlaps and floor perimeter sealed with Isover KB1 adhesive tape
- Fenestration: Replacement A+++ rated glazing units with argon fill and Low-E coating. No change was made to the window frames

- Loft insulation: 170 mm Isover Spacesaver mineral wool quilt (λ 0.043 W/mK) laid above 100 mm existing insulation, perpendicular to the ceiling joists

This retrofit programme provided the opportunity to estimate the HLC of the test house at each retrofit stage using both the coheating and QUB test methods. The staged nature of the test programme meant that the test house HLC was measured under a range of HLCs which included differing rates of fabric and ventilation thermal transmission from the building envelope, as well as differing thermal mass characteristics. Two sets of tests were carried out at each stage of the retrofit over the same testing period. The coheating tests were carried out by a team from Leeds Beckett University and the QUB tests were conducted by a team from Saint-Gobain Recherche. In the next section we present the coheating tests performed and results obtained.

4) Estimating the HLC using coheating

The coheating test is a quasi-steady state method that can be used to obtain an in-situ estimate of the HLC of a building. Bauwens and Roels [11] provide a comprehensive overview of the coheating test. Coheating has existed in various forms since the late 1970's [12,13,14,15] however, there is presently no international standard. Currently, most coheating tests in the UK have been undertaken using the Leeds Beckett University (formerly Leeds Metropolitan University) Whole House Heat Loss Test Method [16].

A coheating test involves heating the internal environment of a building to an elevated, homogenous, and constant temperature with electric resistance heaters and maintaining that temperature over a period of time, usually 1-3 weeks. Air circulation fans are used to increase the consistency of the internal air temperature. The power input to the building, as well as the internal and external environmental conditions, is monitored throughout the test. The coheating test assumes the following whole house energy balance [17]:

$$Q + A_s \cdot S = (\Sigma U \cdot A + C_v) \cdot \Delta T$$

Equation 1

Where **Q** is the total measured power input from space heating in W, **A_s** the solar aperture of the house in m², **S** the solar irradiance in W/m², **ΣU.A** the total fabric transmission heat loss in W/K, **C_v** the background ventilation heat loss in W/K and **ΔT** the temperature difference between the internal and external environment in K.

A modified version of Leeds Beckett University's 2013 Whole House Heat Loss Test Method [16] was used to measure the test house HLC at each retrofit stage. In this study the test house is not subject to solar radiation, so the terms **R** and **S** can be removed from the whole house energy balance [30], and the equation rearranged to show that:

$$HLC = \frac{Q}{\Delta T}$$

Equation 2

To ensure continuous heat flow through the building envelope to the test chamber during the coheating test, a constant ΔT of 15 K was selected. The test chamber HVAC system was set to maintain an air temperature of 5°C. A constant internal air temperature of 20°C was achieved using portable electric resistance heaters located within each room of the test house; each heater was controlled by a fuzzy-logic thermostat connected to a RTD temperature sensor. Two air circulation fans on each floor facilitated a homogenous air temperature throughout the test house. The internal air temperature of the neighbouring house was also maintained at 20°C during each coheating test to minimise inter-dwelling heat transfer across the party wall.

Internal and external air temperatures were measured using shielded RTD temperature sensors. The electrical energy consumption of the heaters, fans and logging equipment was measured using an energy meter with pulse output; registering one pulse per 1 Wh. Measurements of heat flux density through each thermal element were also undertaken during each test using heat flux plates in accordance with ISO 9869 [26]. Data was collected at one minute intervals throughout each test.

For the energy balance in Equation 2 to be strictly valid, a steady state between the internal and external environment should be in existence. A steady state was evident when a constant rate of power input to the test house, and constant rate of heat flow through its thermal elements, was measured. Each coheating test had a minimum duration of 72 hours during which the test house and chamber were left undisturbed. The HLC was derived from measurements obtained during the final 24 hours of each coheating test when a steady state was achieved. Uncertainty for the coheating method in measuring the HLC obtained was calculated by error propagation of the uncertainty associated with the measured variables Q and ΔT in equation 2. The HLC measured during the coheating test at each stage of the retrofit process is provided in Table 3.

Test stage	HLC (W/K)
Full retrofit	69.7 ± 2.9
Full retrofit without floor insulation	82.7 ± 2.8
Solid wall insulation	101.2 ± 2.8
Glazing	174.2 ± 3.2
Loft	180.5 ± 3.2
Baseline	187.5 ± 3.2

Table 3. HLC of the test house each retrofit stage measured during coheating

To allow a direct comparison between the methodologies we performed in addition at each stage of the retrofit a QUB test. In the next section we present the QUB tests performed and results obtained.

5) Estimating the HLC using the QUB method

The QUB method is a means of assessing the HLC of a building in 1-2 days. This method was developed by Saint-Gobain [10,18,19,20] and consists of heating the building with constant power during an initial phase and then letting it cool down with

almost no power during a second phase. The QUB method involves describing the building as a simple resistor-capacitor (RC) model as shown in Figure 2.

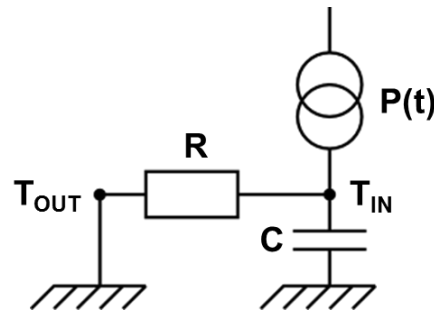

Figure 2: The Resistor-Capacitor (RC) model used in the QUB method for assessing the HLC of buildings.

Two homogeneous temperature nodes, inside and outside the building, are separated by a resistance (R) representing the global thermal resistance of the building. This describes heat losses by transmission and infiltration through the envelope. The inside temperature node is connected to a capacitor (C) which represents the thermal mass inside the building. In field tests it is usually more convenient to measure the power applied to the building so the HLC estimation is usually performed during the night to avoid solar radiation and without occupancy.

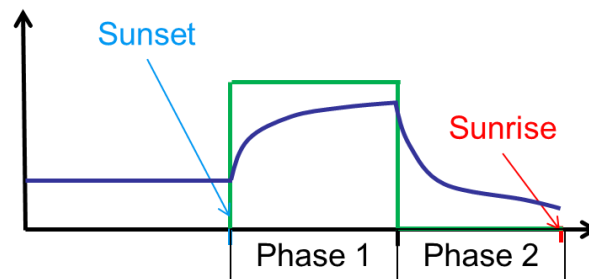

Figure 3: Schematic of temperature development during the two phases.

Figure 3 shows the temperature development through the two phases of the test. At sunset the building is heated with constant power in Phase 1 for a period of a few hours. Phase 2 involves letting the building cool down with almost zero power input for the same duration. In this model the power applied to the building is compensated by the heat loss through the envelope and the heat stored in the building fabric as described in equation 3.

$$P = HLC \times (T_{in} - T_{out}) + C \times dT_{in} / dt$$

Equation 3

Where P is the total power applied to the building in Watts, T_{in} and T_{out} are the inside and outside temperatures respectively in Kelvin. HLC in W/K is the inverse of the whole building resistance R introduced previously and C is the thermal mass in J/K.

It is assumed that the temperature response is a single decaying exponential and that its time constant is the product of the thermal resistance and the thermal capacity of the building. In reality the thermal response is more complex and is the superposition of a large number of decaying exponentials but by performing an

experiment of an adequate length, after some time only the largest time constant plays a role and the previously described model becomes valid.

Using the two successive thermal loads the static HLC can be determined with the following QUB formula:

$$\text{HLC} = (P_1 \times a_2 - P_2 \times a_1) / (\Delta T_1 \times a_2 - \Delta T_2 \times a_1)$$

Equation 4

Where P_i is the total power in Watts used in phase i , ΔT_i is the inside-outside temperature difference at the end of phase i and a_i is the slope of the inside temperature variation at the end of phase i .

There are some experimental conditions that may be used to reduce the duration of the testing procedure [21]. The HLC estimated with a QUB experiment is the product of the static HLC and a corrective factor. This is a result of the superposition of large time constants which still play a role in short experiments. The duration of the experiment can be increased or the heating power can be optimized in order to perform measurement of the HLC by the QUB method. The following criterion for heating power has been identified:

$$P_1 \sim 2 \times \text{HLC} \times (T_{\text{in},0} - T_{\text{out}})$$

Equation 5

Where $T_{\text{in},0}$ is the initial inside temperature and T_{out} the average outside temperature during the experiment.

In order to heat the house quickly and homogeneously it was necessary to use low power sources with low inertia. Aluminum-covered heat mats of around 100 W were rolled and placed vertically to minimize heat exchange with the floor. Most of the energy was therefore dissipated through the air via natural convection. Using this equipment meant that improved reproducibility of the measurements and a homogeneity of the inside air temperature was achieved. The heating was controlled electronically to perform the forced heating and free cooling phases automatically without occupant inside.

Temperature measurements in the centre of each room were taken using a network of thermistor sensors with a resolution of 0.1°C and an accuracy of $\pm 0.5^\circ\text{C}$ within the range 10°C to +85°C. The monitoring system allowed for many readings, including gas and electricity consumption, to be recorded as well as all the sensors in the house. The inside temperature considered was calculated using volume weighted averages. Uncertainty was calculated by error propagation in the equation 4. For each parameter entering this equation we calculate the uncertainty associated to it. This reflects the uncertainty linked to the quality of the temperature measurements (temperature homogeneity, sensors accuracy, etc.) and so the uncertainty due to the experimental apparatus (heating system and sensors) used. It does not integrate the uncertainty linked to the choice of the model which could lead to a systematic bias. This work is still on-going and will be published in a separate paper. The summary of the results obtained for the different stages of the retrofit where a single measurement had been performed is shown in table 4.

Test stage	Full retrofit	Full retrofit without floor	Solid wall insulation	Glazing	Loft	Baseline
Heating duration (hh:mm)	3:38	0:35	3:57	3:59	3:59	3:58
Equation 5 criterion for heating power (W)	1907	2594	3090	5463	5511	5658
P1 (W)	2495	2984	3418	4946	5415	5912
a1 (°C/hour)	0.42 ± 0.05	2.39 ± 0.23	0.37 ± 0.04	0.29 ± 0.03	0.4 ± 0.03	0.45 ± 0.05
ΔT1 (°C)	16.4 ± 0.4	17 ± 0.4	18.4 ± 0.4	19.2 ± 0.17	19.4 ± 0.4	19.7 ± 0.5
P2 (W)	125	303	136	150	139	141
a2 (°C/hour)	-0.33 ± 0.06	-2.1 ± 0.2	-0.45 ± 0.07	-0.63 ± 0.08	-0.64 ± 0.09	-0.68 ± 0.09
ΔT2 (°C)	14.1 ± 0.4	15.9 ± 0.4	14.7 ± 0.4	13.5 ± 0.4	13.4 ± 0.5	13.1 ± 0.5
QUB HLC (W/K)	77 ± 8	95 ± 6	116 ± 8	198 ± 8	198 ± 10	212 ± 11

Table 4: QUB parameters assessed during the various measurements and results for the HLC identified.

Finally in the next section we compare and discuss all the results obtained.

6) Discussion

Figure 4 shows a comparison of the HLC between the coheating tests for each stage of the retrofit with the QUB tests. During the full retrofit without floor QUB test the heating phase stopped after half an hour due to an electrical issue. Despite this shortened time the results were found to have less than a 15% difference with the coheating result.

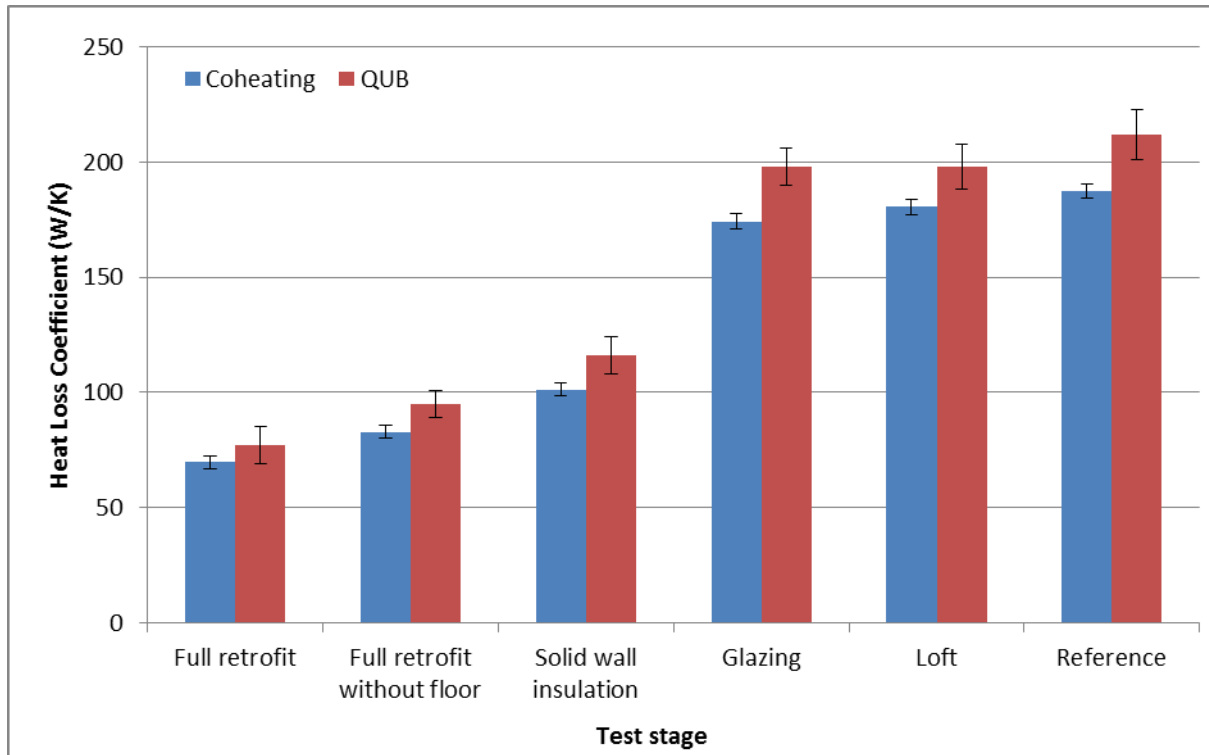

Figure 4: Comparison of HLC identified by coheating and QUB tests for the various stages.

A close correlation between the two testing methodologies at all stages of retrofit is apparent. This demonstrates that the QUB method is a useful tool in determining whole building heat loss in a relatively short period of time, less than 8 hours in these experiments. It can also be seen that the QUB method is robust as indicated by the correlation with the results from coheating at all stages of retrofit.

A maximum deviation of 15%, with an average deviation of around 13%, was obtained at the solid wall insulation stage. These results demonstrate that both methodologies are very powerful tools to determine whole building heat loss.

These results have been obtained using a unique testing facility within a climatically controlled chamber with constant external temperature and no solar radiation. Validation in the field remains to be done.

By performing the retrofit by stages the contribution of each stage to the whole house HLC can be determined. This is summarised in Table 5.

	Coheating HLC gain in W/K (% of the ref. HLC)	Uncertainty in W/K (%)	QUB HLC gain in W/K (% of the ref. HLC)	Uncertainty in W/K (%)
Full retrofit	-117.8 (-63)	4.3 (3)	-135.0 (-64)	13.6 (7)
Floor insulation	-13.0 (-7)	4.0 (2)	-18.0 (-8)	10.0 (5)
Solid wall insulation	-86.3 (-46)	4.3 (2)	-96.0 (-45)	13.6 (7)
Glazing	-13.3 (-7)	4.5 (2)	-14.0 (-7)	13.6 (6)
Loft	-7.0 (-4)	4.5 (2)	-14.0 (-7)	14.9 (7)
Estimation based on the sum of single element upgrade	-119.6 (-64)	8.7 (5)	-142.0 (-67)	26.3 (13)

Table 5. HLC gain for each stage identified using coheating and QUB

The uncertainty of each upgrade is higher using QUB than coheating. This can be explained by the duration of the measurement which is much shorter than when using coheating. In cases when the measurement is of relatively modest improvements of thermal performance coheating will be more accurate. In cases when the time of measurement is important QUB will be advantageous.

With regards to individual upgrade measures, it is apparent that the greatest improvement is obtained when using solid wall insulation, with around a 46% reduction of heat loss. This is reasonable as the greatest heat loss area is the opaque walls. The improvements from glazing, floor and loft insulation contribute reductions of 7%, 7% and 4% respectively. These lesser improvements are due to the smaller ratio of associated heat loss area compared to the whole area and by the minimum loft insulation and glazing elements in the baseline case.

Finally, from the measurements of each element's contribution we can estimate the full retrofit improvement by combining them. This estimation differs by less than 1% of the whole HLC from the coheating tests and less than 4% for the QUB method. This suggests that there is no additional contribution coming from the combination of element upgrades, nor a higher loss that could be caused by thermal bridging. This must be considered as the uncertainty is comparable to the difference. From the coheating measurements uncertainty there is a maximum potential difference of 5% of the reference HLC. This must be compared to the large improvement from thermal insulation which is almost 63% of the reference HLC.

7) Conclusions

In this paper we have presented a unique experiment that assessed the HLC of a retrofitted building located in a climatic chamber. In this facility there is a lack of realistic boundary conditions but it serves as a useful starting point for external field validation work, which is currently ongoing. Starting from a baseline representative of the current UK house stock element upgrades of each component using widely available retrofit products were performed. At each stage two different measurements to assess the HLC of the building were taken. First, a reference measure was obtained using a modified coheating methodology equivalent in this case to a static measurement. Secondly, the QUB method was used to investigate

the possibility of reducing the duration of a measurement without a significant loss of accuracy.

With regards to the methodologies used we showed that both methodologies can be used to assess the HLC of a building in this range of thermal inertia and insulation level of the building in this climate chamber. Coheating appears to be an accurate method for thermal diagnosis whereas QUB provides a reasonable accuracy in a much shorter duration. These methods have a given uncertainty which must be considered.

Although it can appear difficult to use these measurements to guarantee less than 10% in small improvements of the fabric, significant retrofit actions can be assessed using these methods. It could be used to qualify the thermal performance of buildings to be retrofitted to assess the potential need of envelope improvements. It could also be used at the commissioning stage of new-built or retrofitted buildings to validate the predicted thermal performance.

Acknowledgements

We would like to thank S. Gibson for project management, Jacob Eco Energy Ltd for construction works, Saint-Gobain Businesses for construction materials support and construction works and Saint-Gobain Corporate R&D for funding. Additional thanks go to Matthew Brooke-Peat, Dominic Miles-Shenton, Callum Cuttle, Professor Chris Gorse, and Mo Benjaber for their contributions to the project.

References

- [1] Stafford, A., Bell, M. and Gorse, C. (2012) *Building Confidence - a working paper*. Centre for Low Carbon Futures report No. 008. Available from: <www.lowcarbonfutures.org.uk/reports/research-reports> [Accessed January 2014].
- [2] Johnston, D., Miles-Shenton, D., Farmer, D. (2015). Quantifying the domestic building fabric 'performance gap'. *BSERT*, 2015, Vol 36(5) 614-627. Doi:10.1177/0143624415570344.
- [3] Zero Carbon Hub. (2014). Closing the gap between design and as built performance. London. Retrieved from http://www.zerocarbonhub.org/sites/default/files/resources/reports/Design_vs_As_Built_Performance_Gap_End_of_Term_Report_0.pdf
- [4] DECC. (2015). Domestic energy consumption in the UK between 1970 and 2014. Retrieved March 29, 2016, from https://www.gov.uk/government/uploads/system/uploads/attachment_data/file/449134/ECUK_Chapter_3_-_Domestic_factsheet.pdf
- [5] European Environment Agency. (2009). Energy efficiency and energy consumption in the household sector. Retrieved from <http://www.eea.europa.eu/data-and-maps/indicators/energy-efficiency-and-energy-consumption-5/assessment>
- [6] Swan, W., Fitton, R., & Brown, P. (2015). A UK practitioner view of domestic energy performance measurement, 168(3), 140–147. <http://doi.org/10.1680/ensu.14.00056>
- [7] Palmer, J., & Cooper, I. (2013). Housing Energy Fact File.

- [8] Stevenson, F. (2013). Reducing energy demand through retrofitting buildings. *Building Research & Information*, 41(5), 605–608. <http://doi.org/10.1080/09613218.2013.799730>
- [9] Johnston, D., Miles-Shenton, D., Wingfield, J., Farmer, D., & Bell, M. (2010). *Whole House Heat Loss Test Method (Coheating)*. Leeds: CEBE.
- [10] Mangematin, E., Pandraud, G., and Roux, D. (2012). Quick measurements of energy efficiency of buildings. *Comptes Rendus Physique*, 13(2012):383-390. doi:10.1016/j.crhy.2012.04.001
- [11] Bauwens, G., & Roels, S. (2014). Co-heating test: A state-of-the-art. *Energy and Buildings*, 82, 163–172. <http://doi.org/10.1016/j.enbuild.2014.04.039>
- [12] Farmer, D., Johnston, D. and Miles-Shenton, D. (2016) Obtaining the heat loss coefficient of a dwelling using its heating system (integrated coheating), *Energy and Buildings*, 117, pp.1-10. DOI: 10.1016/j.enbuild.2016.02.013
- [13] Sonderegger, R. C., Condon, P. E., Modera, M. P. (1979). In-situ measurements of residential energy performance using electric coheating. *ASHRAE Transactions*, 86(1):1980. LBL-10117.
- [14] Sonderegger, R.C., and Modera, M.P. (1979). Electric coheating: a method for evaluating seasonal heating efficiencies and heat loss rates in dwellings. *Proceedings of Second CIB Symposium on Energy Conservation in the Built Environment*, Copenhagen, 1979. Lawrence Berkely National Laboratory: LBL-8949.
- [15] Ortega, J. K. E., Anderson, J. V., Connolly, J. M., Bingham, C. E. (1981). An electric coheating experiment to determine the heat-loss coefficient of a double—envelope house. *Proceedings of the AS/ISES Sixth National Passive Solar Conference*, Portland, Oregon. 8-12 September 1981.
- [16] Johnston, D., Miles-Shenton, D., Farmer, D. and Wingfield, J. (2013). *Whole house heat loss test method (Coheating)*. Centre for the Built Environment, Leeds Metropolitan University (renamed Leeds Beckett University). June 2013.
- [17] Everett, R., Horton, A., and Doggart, J. (1985). *Linford Low Energy Houses, Technical Report*. Open University Energy Research Group: Milton Keynes, UK.
- [18] Fitton, R., Pandraud, G. (2013) QUB: Validation of a Rapid Energy Diagnosis Method for Buildings. International Energy Agency Annex 58 4th Expert meeting – April 8-10, 2013 – Holzkirchen, Germany
- [19] Bouchie, R., Alzetto, F., Brun, A., Weeks, C., Preece, M., Muhammad, A., Sisinni, M. (2015). *D1.2 Methodologies for the Assessment of Intrinsic Energy Performance of Buildings Envelope*. Final Report of the PERFORMER Project, FP7-2013-NMP-ENV-EeB:609154:2015.
- [20] Pandraud, Mangematin, Roux and Quentin, QUB: a New Rapid Building Energy Diagnosis Method, *Proceedings in Clima 2013*
- [21] Pandraud, G., Gossard, D. and Alzetto, F. (2014). Experimental optimization of the QUB method. IEA EBC Annex 58, 6th expert meeting, Ghent, 14-16 April 2014.
- [22] Ji, Y., Fitton, R., Swan, W. and Webster, P. (2014). Assessing the overheating of the UK existing dwellings – A case study of replica Victorian end terrace house. *Building and Environment*, 77, 1-11. Doi:10.1016/j.buildenv.2014.03.012.
- [23] Swan, W., Ruddock, L., Smith, L., & Fitton, R. (2013). Adoption of sustainable retrofit in UK social housing. *Structural Survey*, 31(3), 181–193.

- <http://doi.org/10.1108/SS-12-2012-0039>
- [24] Boardman, B. (2006). The Challenge of Existing UK Houses. In IABSE Henderson Colloquium. Cambridge: Factor 10 Engineering for Sustainable Cities
 - [25] Ravetz, J. (2008). State of the stock—What do we know about existing buildings and their future prospects? *Energy Policy*, 36(12), 4462–4470. <http://doi.org/10.1016/j.enpol.2008.09.026>
 - [26] ISO (1994), *ISO 9869: Thermal Insulation – Building Elements – In-situ Measurement of Thermal Resistance and Thermal Transmittance*. International Organisation for Standardisation: Geneva, Switzerland.
 - [27] Palmer, J., Pane, G., Bell, M., & Wingfield, J. (2011). *Comparing primary and secondary terms analysis and re-normalisation (PStar) test and co-heating test results*. London. Retrieved from <http://webarchive.nationalarchives.gov.uk/20120919132719/http://www.communities.gov.uk/documents/corporate/pdf/1898592.pdf>
 - [28] Fels, M. F. (1986). PRISM: An Introduction. *Energy and Buildings*, 9, 5–18.
 - [29] Swan, W., Fitton, R., Gorse, C., Farmer, D. and Benjaber, M., 2017. The staged retrofit of a solid wall property under controlled conditions. *Energy and Buildings*, 156, pp.250-257
 - [30] Farmer, D., Gorse, C., Swan, W., Fitton, R., Brooke-Peat, M., Miles-Shenton, D. and Johnston, D., 2017. Measuring thermal performance in steady-state conditions at each stage of a full fabric retrofit to a solid wall dwelling. *Energy and Buildings*, 156, pp. 404-414