



LEEDS
BECKETT
UNIVERSITY

Citation:

Marino, MD (2018) Architectural Impacts of RFIop: RF to Address I/O Pad and Memory Controller Scalability. IEEE Transactions on Very Large Scale Integration (VLSI) Systems. ISSN 1063-8210
DOI: <https://doi.org/10.1109/TVLSI.2018.2821004>

Link to Leeds Beckett Repository record:

<https://eprints.leedsbeckett.ac.uk/id/eprint/4937/>

Document Version:

Article (Accepted Version)

The aim of the Leeds Beckett Repository is to provide open access to our research, as required by funder policies and permitted by publishers and copyright law.

The Leeds Beckett repository holds a wide range of publications, each of which has been checked for copyright and the relevant embargo period has been applied by the Research Services team.

We operate on a standard take-down policy. If you are the author or publisher of an output and you would like it removed from the repository, please [contact us](#) and we will investigate on a case-by-case basis.

Each thesis in the repository has been cleared where necessary by the author for third party copyright. If you would like a thesis to be removed from the repository or believe there is an issue with copyright, please contact us on openaccess@leedsbeckett.ac.uk and we will investigate on a case-by-case basis.

Architectural Impacts of *RFiop*: *RF* to Address *I/O* Pad and Memory Controller Scalability

Mario D. Marino *Member, IEEE*, Leeds Beckett University, m.d.marino@leedsbeckett.ac.uk

Abstract— Despite power boundaries, Moore’s law is still present via scaling the number of cores, which keeps adding demands for more memory bandwidth requested by these cores. To obtain higher bandwidth levels it is fundamental to address memory controller (MC) scalability. However, MC scalability growth is limited by I/O pin counts scaling. To underline MC and pin scaling, a radio frequency(*RF*) *I/O* pad-scalable package-based (*RFiop*) memory organization is further investigated.

In *RFiop*, a radio-frequency pad (RFpad) is defined as a quilt-packaging (QP) coplanar waveguide (CPW) employed at radio-frequency (RF) ranges. An RFpad connects a rank to an RFMC which is formed by coupling MCs to RF TX/RX. By using QP package to explore the architectural benefits of laying out ranks, *RFiop* replaces the traditional memory path with an RF-based one, whilst exploring the scalability of RFpads/RFMCs via RF signaling. When evaluating *RFiop*, our findings show that bandwidth/performance are enhanced by around 4.3x which can be viewed as a diminution in transaction queue occupancy/latency as well as using a reduced and scalable 4-8 RFpads per RFMC. *RFiop* architectural area benefits allow bandwidth/performance improvements of around 3.2x, whilst reducing interconnection energy up to 78%.

Index Terms—memory, controller, bandwidth, I/O pin, RF

I. INTRODUCTION

Given Moore’s law lasting behaviour, higher transistor densities have allowed core count growth along different processor generations. Other than the dominant and restrictive power wall problem, as more cores are included, memory bandwidth contention is further increased, which is likely to decrease performance. On the applications side, internet of things[1] and big data science applications are likely to further increase the pressure on the memory system.

Current digital memory design has mostly focused on (i) frequency rather than (ii) width, whilst keeping area/density upper boundary limits for I/O pad/pin counts[2]. For example, (i) current DDR-solutions present typical memory data rates in the 1333-2400MT/s range in multicores, up to 5000MT/s in manycores, and 667-1333MT/s in embedded ones[2].

Given that larger frequencies dramatically impact power, memory parallelism via larger (ii) widths is a potential solution. Larger widths can be explored via (ii.1) a larger number of memory controllers (MCs) and/or via employing (ii.2) ranks (which are commercially known as dual in-line memory module or DIMM, that are sets of memory banks with data output aggregated and sharing addresses) with larger widths.

(ii.1) Having larger width means employing a larger number of MCs (MC counts or MC scalability). Despite low cost and proper design alternative for low numbers of MCs, given ITRS

pin-count limitations[3], as cores count tend to tens/hundreds, DDR technologies present significant I/O pin counts scalability restrictions, thus limiting the number of MCs, which further restricts bandwidth and performance. For example, 16-core Bulldozer[4] and 64-core Tile64[5] processors have 4 MCs.

More advanced commercial solutions such as Intel FBDIMM[6], Hyper Memory Cube (HMC)[7], and RAMBUS XDR2[8] all of which even employing serialization, accompanied by adaptive equalization in the latter one, are still bound by unscalable I/O pins, which restricts the scalability of the number of MCs and as a consequence bandwidth benefits. Alternatively, using (ii.2) much wider ranks and presenting no I/O pins/scalability restrictions, scaling MCs in 3Dstacking is reported[9] to be limited by temperature when scaling ranks, thus restricting memory parallelism.

Optical- and radio-frequency-(RF)-based memory are technologies that combine telecommunication transmission techniques and fast media on the memory path to address I/O pin scalability. Former solutions employ wavelength division multiplexing (WDM) and optical fibers to connect processor and memory through optical MCs and scalable optical-pins[10]. Still restricted in terms of development costs, optical transmission has advanced significantly in regards to temperature sensitiveness[11]. Instead, by sharing manufacturability with CMOS, RF shares its low costs, whilst remaining advantageous in terms of energy and millimeter-range delays when compared to optical transmission as reported in [12].

Very importantly, being appointed[13] as one of the areas that can improve processor performance the most, Tam et al.[14] state that in the 1-10cm range (which is well within regular package distances[13]) RF-transmission is more energy-efficient than optical and digital (traditional) ones.

Coplanar waveguide (CPW)¹ and microstrip² are examples of types of RF-interconnection that could be employed along the memory path and placed on-package. In particular, CPW quilt-packaging (QP)³ lines[15] were prototyped and manufactured, which demonstrates the viability of an on-package

¹CPW is an RF waveguide that has a central metallic strip line composed of two different slits, which are separated by a ground plane; the strip is manufactured on the upper part of the dielectric.

²Generally employed in RF on-chip communications and composed by a trace of metal on top of a substrate.

³quilt packaging (QP) is a technique where quilt lines [15] are introduced: these lines are coplanar waveguides (CPW) built as extensions of the processor and memory dies coupled to face each other to enable a low return loss. As CPWs, QP present RF properties, therefore these lines can be used as an RF-interconnection.

RF-interconnection that could be used to connect processor to memory.

In the RF domain of scalable-width solutions, *RFiop* system employs the package area which fits ranks (which are assumed to be manufactured as dies) and QP lines to connect ranks and MCs as a likely solution to improve bandwidth. Exploring Polka et al.'s[13] guidelines towards improving bandwidth on the package area, compared to *RFiop* organisation [16] previously proposed, this report further leverages the space of scalable-width memory solutions through the following contributions:

- Given potential growth on the number of cores, *RFiop* bandwidth and latency are further evaluated and a sensitive analysis is performed under a larger number of cores (twice as the previous publication).
- Through detailed-accurate system simulation, *RFiop* performance, area and power architectural implications are further investigated when replacing MC with an equivalent RFMC, whilst the most important ones are identified.
- An RF behavioral model of the RFpads (which are defined as QP lines in [16]) is introduced. This model includes the following important RF parameters: insertion loss (*IL*), return loss (*RL*) and crosstalk noise (*CN*). Since RFpads are QP lines, the model is obtained from regression over QP RF simulations performed in [15]. To the best of our knowledge, it is the first time that such model used to determine previously mentioned losses is developed using regression. The model allows the designer to predict the RF behavior of RFpads for a wide RF bandwidth (*BW*) range and appropriate for future memory solutions.
- Given the wide variability and complexity of DDR systems, a further validation of the benefits of *RFiop* for different types of memories with different settings (such as different data rates and timing parameters) and different memory generations is performed. Furthermore, the scalability investigation of the number of RFpads for faster memories is further extended.
- Several area and power/energy benefits of *RFiop* are newly presented and discussed including RFMCs versus traditional MCs comparisons.
- Not previously covered, *RFiop* is compared to other state-of-the-art memory systems such as HMC[7] and its manufacturing viability.
- To the best of our knowledge, not previously discussed, this study demonstrates that scaling ranks laid out on the package area presents lower temperature restrictions than stacking ranks (3Dstacking).
- Further *RFiop* architectural benefits are investigated for other bandwidth-bound benchmarks.
- Further approaches to *RFiop*'s limitations are analysed.

The rest of this paper is organized as follows: section II introduces the motivation of the I/O pad/pin problem. Section III presents *RFiop* and compares RF technology to other advanced solutions in terms of approaching the I/O pin/pad problem. Section IV describes the experiments whilst Section

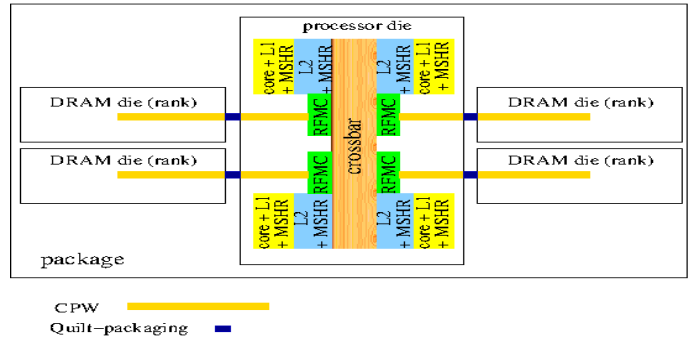

Fig. 1: *RFiop* reduced floorplan: 4 RFMCs and 4 ranks, from [16]

V depicts the related work. Section VI concludes the paper.

II. MOTIVATION, BACKGROUND, MECHANISMS TO ACHIEVE PIN/PAD SCALABILITY AND RF BACKGROUND FOR RFPADS

In this section, the impact of the I/O pin problem on the bandwidth limitations and pin/pad count scalability is illustrated through a sequence of steps. Next, a formulation is introduced to show the approach of current memory technologies and common optical/RF memory mechanisms to respectively achieve higher bandwidth-per-pin/pad as well as to promote pin/pad scalability. In addition and very importantly, RF background is introduced to facilitate understanding RFpads behavior.

A. Motivation: The I/O pad/pin problem

A baseline reference should be defined to estimate *RFiop* further architectural benefits. The baseline strategy determination proposed in [16] is adopted to establish likely bandwidth/pin requirements. In this strategy, for processors currently in the market, the number of cores as well as a minimum threshold for the number of MCs and pins is determined. For example, for a 2-core traditional out-of-order (OOO) microprocessor, 1 MC is typically utilized, whilst for a 4-core microprocessor, 2MCs are employed, and for a 16-core one, 4MCs[4] are used. In this example, by observing core count and number of MCs for DDR-family generations, a logarithmic behavior for the MC counts as a function of the number of cores can be noted, and a likely estimation for a future 32-core-OOO processor is 5MCs (which is defined in this study as the baseline MC count), thus core:MC ratio is 32:5.

Using the reports from Polka et al. [13] and ITRS [3] predictions, in combination with the previously determined core:MC ratio, pin-counts are estimated next.

To understand the bandwidth requirements of a likely 32-core system, a bandwidth characterization is proposed. In this characterization, in order to guarantee that addresses are equally distributed along the ranks so that any advantage is taken on locality[17], the most conservative addressing mode is adopted by interleaving cache lines along the RFMCs and closed page mode (server) employed in all experiments.

The characterization experiments are divided in two sets: (i) in the first, bandwidth of one rank is derived to calibrate/validate the system; (ii) in the second, (i) is extended to the maximum core:MC ratio, whilst comparing bandwidth

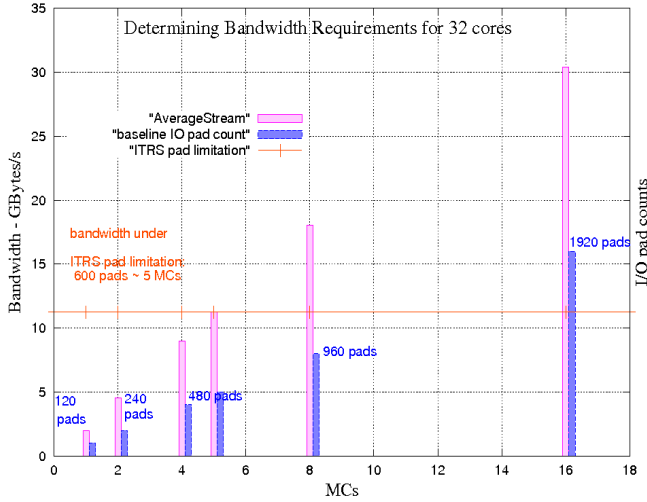

Fig. 2: determining bandwidth demands and pad requirements to reach core:MC ratio of 32:16

and pin count in both of them. A detailed list of the parameters used in these experiments can be found in Table IIIa.

The rank selected to perform the bandwidth characterization (i) scaling is a generic 1GB-DDR3 DIMM, with 64-data-bit, 1333 MT/s-data-rate, based on Micron MT41K128M8[2] (Table IIIa). MCs are individually connected to independent ranks to extract their maximum bandwidth. In this characterization, two experiments are performed: in (i), core:MC ratio adopted is 1:1 and this baseline system is modeled as a set of one core/MC/crossbar/selected rank (settings in Table IIIa) using M5[18] and DRAMsim[17] simulators whilst bandwidth is measured utilizing an average of STREAM[19] benchmarks. This experimentation reports a 2.5 GBytes/s-bandwidth, which confirms its proper calibration and validity, since it fits within the bandwidth magnitude range reported by Micron[2].

Experiment (ii) starts with determining the number of pins employed on each rank: as a first observation, in a regular chip, 50% of the total pads are destined to power purposes whilst the other 50% are destined to the remaining signals. Further investigation of Micron manuals[2] shows that 50% of 240 pins available, i.e., around 120 pads, are dedicated to control/data signals, whilst the rest are dedicated to power.

To estimate the maximum number of MCs that fit on the on-package area, Marino’s assumptions[16] are utilized: 16 ranks dies can be fit within the package area and each rank is connected to a different MC (thus 16MCs) so that bandwidth of each rank can be fully explored. Therefore, by employing the previously assumed 32 cores, the core:MC ratio is 32:16.

The same simulators and benchmark suite in (i) are used in (ii), but using 32:16 core:MC ratio rather than the 1:1 core:MC one, as well as scaling pads counts linearly with MC counts. The results of this scaling are reported in Figure 2, where it is observed that 1920 pads (or 3840 pins using the same pad:pin of 1:2 previous assumed proportion) are needed to achieve 32:16 core:MC ratio – 30.4GB/s-bandwidth, which corresponds to a significant larger amount than the ITRS upper limit of 1023 pads [3]. These findings show that when comparing the

maximum bandwidth obtained for core:MC ratio of 32:16 to the baseline (which has core:MC ratio of 32:5), a significant larger bandwidth improvement factor of 2.7x (30.4GB/s over 11.25GB/s) is obtained. As a conclusion, larger MC-counts significantly benefit bandwidth, which motivates the search for pin-scalable solutions.

B. Background: Current memory solutions do not scale

The main focus of current commercial solutions [2] consists of maximizing memory bandwidth by generally increasing the frequency and/or the width of the bus that connects MC to the rank, whilst keeping MC counts at lower magnitudes due to pin restrictions. To start to understand how commercial strategies employ current design parameters, we begin with:

$$bsr = memory_bus_width * freq_multiplier * freq \quad (1)$$

where bsr represents the maximum bandwidth supplied by the rank, $memorybuswidth$ the width of the memory bus, $freq_multiplier$ the bus frequency multiplier, and $freq$ the frequency of the memory bus. For a pad, we define:

$$bpp = bsr / number_of_available_iopads \quad (2)$$

where bpp is the bandwidth per pad and $number_of_available_iopads$ the number of available I/O pads.

As previous experiments have illustrated, current DDR3 memories present around 180-240 I/O pins/MC [2], which are clearly not scalable. Furthermore, using equation 2 with the significant magnitude range of 32-55 pin-range to represent a large amount of pins as in commercial solutions (e.g. Intel FBDIMM[6] with 48 pins/MC and 2.5 Gbits/s/pin; RAMBUS XDR2[8] with 32 pins/MC and 12.8 Gbits/s/pin, HMC[7] with 55 pins/MC and 10 Gbits/s/pin; typical DDR ranks[2] with 123 MC pins and 1.2-5 Gbits/s/pin), lower bandwidth-per-pin rates are obtained, which still remain a challenge when more bandwidth is required, thus motivating the search for pad/pin-scalable solutions.

C. Mechanisms to Achieve Pin/Pad Scalability: optics and RF

In this section, the trade-offs involved when adopting RF/optical technologies to approach pin/pad scalability are explained via modeling modulation signaling principles.

In both RF and optics, high MC scalability can be obtained via modulation combined to very low latencies (light or high-frequency speed transmission) respectively over electrical wires or fiber. Equation 1 is modified to estimate the benefits of modulation. Using $total_data_rate$ or tdr results in:

$$tdr = number_carriers * data_rate_per_carrier \quad (3)$$

$$bpp = tdr / number_of_available_iopads \quad (4)$$

where $number_carriers$ also represents the number of wavelengths when optical systems are referred. For example, optical Corona [10] is reported to have 2 I/O optical-pins, i.e., 2 optical fibers between MC and the ranks, thus scalable. In this case, equation 4 applied in Corona [10] indicates that:

$$bpp = 160GBytes/s / 2pin = 640GBits/s/pin, \quad (5)$$

which is much larger than maker solutions (12.8 Gbits/s/pin [8]). Similarly, as further explained, typical 30-140Gbits/s data rates used in RF are able to support typical DDR-data

RF technology (nm)	45	32	22
carriers	10	12	14
data rate per band (Gbits/s)	7	8	10
total data rate per wire(Gbits/s)	70	96	140
Max CMOS RF carrier freq(GHz)	592	768	944
space between carriers(GHz)	28	32	36
power (mW)	60	72	84
energy per bit(pJ/bit)	0.85	0.75	0.6
area (TX + RX) (mm ²)	0.0115	0.0119	0.0123
area/(data rate) (um ²)/Gbits/s	164	124	88

TABLE I: RF-interconnection replicated from [12] when modeling RF technology and from ITRS[3]

rates using a low amount of wires/pads-counts. Next, an RF background and modeling are provided to understand the RF behaviour of the RFpads.

D. RF background for RFpads

To facilitate understanding RFpads RF behavior, a simple modeling by Liu [15] is adopted. In this model, the characteristic impedance of a QP line is defined as Z_0 , when the load impedance Z_l is different from Z_0 . Having a wave at the termination reflected to the generator enables to define the reflection coefficient at the termination ($\gamma(l)$) as the ratio of the reflected wave to the incident wave the following way:

$$\gamma(l)l = V_0 + /V_0-, \text{ or} \quad (6)$$

$$\gamma(l) = (Z_l - Z_0)/(Z_l + Z_0) \quad (7)$$

where V_0+ is the incident wave amplitude at $z = 0$, and V_0- the amplitude reflected to the load. Return loss (RL) is defined as available power at the transmission line that will not be delivered thoroughly to the load, and represented (dB) as:

$$RL = 20.log\gamma(l)dB, \text{ or} \quad (8)$$

$$RL = 20.log(S_{11})dB \quad (9)$$

Given that the reflection coefficient $\gamma(l)$ at a distance l from the load can be expressed as:

$$\gamma(l) = \gamma(l).exp(2.j.\beta.l).exp(2.\alpha.l) = \gamma(l).exp(2.\gamma.l) \quad (10)$$

Then, input impedance Z_{in} can be defined as:

$$Z_{in} = V(l)/I(-l) = Z_0.(Z_l + Z_0.tanh\gamma.l)/(Z_0 + Z_l.tanh\gamma.l) \quad (11)$$

where $V(-l)$, $I(-l)$, Z_0 and Z_l are respectively the voltage, current at distance l from the load, impedances at distance 0 and l . With those, the power delivered (P_{in}) to the transmission line at $z = -l$ can be represented as:

$$P_{in} = [V(-l).I(-l)] = |V_0+|^2/(2Z_0).[1 - \gamma(l)^2].exp(2.\alpha.l) \quad (12)$$

and the power loss through the transmission line can be defined as the difference between P_{in} and P_l , represented as:

$$P_{loss} = P_{in} - P_l = |V_0+|^2/(2Z_0).2.[(exp(2.\alpha.l) - 1) + \gamma(l)^2].(1 - exp(-2.\alpha.l)) \quad (13)$$

Defining reflection coefficient at the source (γ_g) and Z_0 as:

$$\gamma_g = (Z_g - Z_0)/(Z_g + Z_0) \text{ and} \quad (14)$$

$$Z_o^2 = Z_r.[[(1 + S_{11})^2 - S_{21}^2]/[(1 - S_{11}) - S_{21}]] \quad (15)$$

insertion loss (IL) can then be defined as the ratio of power of the load to the power from the generator:

$$IL = 20.log(S_{21})dB \quad (16)$$

Alternatively, as defined by Liu[15], using a symmetric general two-port transmission line from port 1 (if a simple imaginary line considers port 1 to the left of port 2, at V_1 voltage, V_1+ direction to the right, V_1- signal direction to the left) to port 2 (at V_2 voltage, to the right of port 1, V_2+ signal direction to the left, and V_2- signal direction to the right), S_{11} and S_{21} parameters, can be defined as:

$$\begin{aligned} S_{11} &= V_1 - /V_1 + \text{ with } V_2+ = 0 \\ S_{21} &= V_2 - /V_1 + \text{ with } V_2+ = 0 \end{aligned} \quad (17)$$

In the above model, RL is represented by S_{11} and IL by S_{21} . Very importantly, the previous equations represent a general and simple CPW model. According to Liu[15], it is very challenging to represent and quantify QP lines parameters using closed equations such as those exemplified previously due to CPW frequency-dependent parameters and complex discontinuities between different parts of its structures, especially at high bandwidth (BW).

To approach these challenges in QP[15], Ansoft HFSS 3D electromagnetic field solver simulator[20] was adopted to determine $RL(S_{11})$, $IL(S_{21})$ and crosstalk noise (CN) of a QP CPW. In the report[15], Liu performed a very wide range of CPW simulations with different widths (100 μ m, 50 μ m, 20 μ m and 10 μ m), different silicon substrate resistivities and a wide range of BW : 0 to 40GHz for (100 μ m and 50 μ m) and 0 to 200GHz for (20 μ m and 10 μ m).

Furthermore, besides RL and IL , crosstalk (CN) was also investigated by Liu[15]. By simulating with several ground-lane configurations between QP lines, Liu[15] shows that isolation between different QP lines is improved.

As a result, many different curves of RL , IL and CN were obtained for a wide variety of frequencies. While Figure 4a illustrates obtained RL , IL and CN , these parameters proportionally increase with the increase of the frequency. RF behavior is further approached in Section IV-B.

III. RFiop

In this section, $RFiop$ memory organization techniques explore RFpad scalability which enables RFMC scalability. In order to have I/O pin counts minimized to achieve RFMC scalability, memory channels are best matched with RF. Whilst minimizing I/O pin counts of each individual MC, the total pin count must be scalable targeting bandwidth increase as well as keeping power utilization within low levels.

A. RFiop Overview and General Design rules

A general view of $RFiop$ can be found in Figure 3. $RFiop$ employs the following strategies: (1) minimal amount of elements designed for RF and also (2) for short distances.

Figure 1 illustrates $RFiop$'s memory path: its memory path is composed of (1) RFMCs – formed by coupling MCs to RF transmitters (TX) and receivers (RX), and placed at the

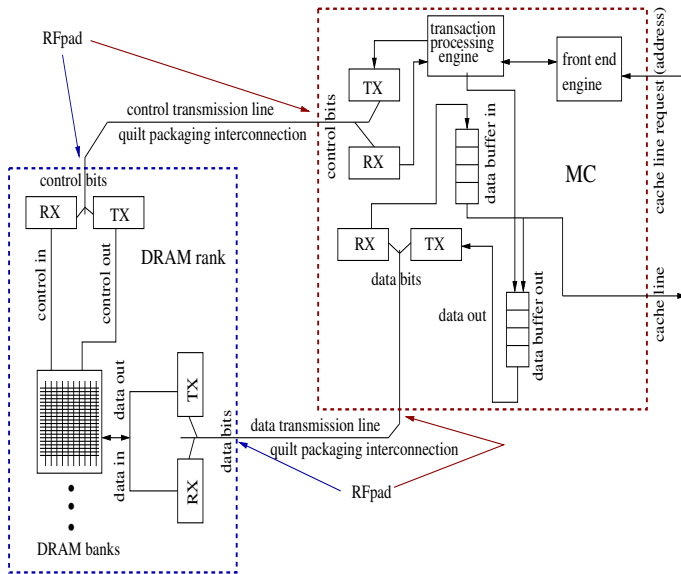

Fig. 3: *RFiop* scheme [16].

processor die, (2) off-die RF-interconnection lines, and (3) by on-package ranks placed on the rank dies in a coplanar fashion. In each RFMC, RF TX/RX are responsible for modulating/demodulating data/commands. Modulated signals (RF waves) are transmitted/received through the RF QP lines. To address RF-transmission challenges, lesser elements such as RF TX/RX at the RFMCs, RFpads (QP) and ranks are employed when compared to typical solutions [21].

Furthermore, the fact that in *RFiop* all elements are properly designed for RF minimizes the previously mentioned RF degradation effects (RL , IL and CN). The short distances employed in *RFiop* can be traversed through QP lines which connect the RFMCs to ranks and allow significantly lower degradation effects than those along long printed-circuit-board (PCB) as reported in [22].

B. Ranks manufactured as dies and rank width

Before other new technologies such as HMC[7] were developed, *RFiop* employed ranks manufactured as DDR dies, each die containing its proper set of TX/RX to be able to communicate with the RFMCs (at the processor die). In *RFiop*, the fact that ranks operate as traditional DDR elements allows compatibility with memories in the market, thus not requiring any protocol or memory timing change. In Figure 1, a memory die with its RF TX/RX is connected to the core (with its RFMCs, i.e., MCs coupled to RF TX/RX). To keep DDR compatibility along future DDR-memory generations, *RFiop* employs typical DDR-rank width, i.e., 64 bits (8 Bytes) [2]. The width aspect is further discussed.

C. *RFiop* signal path

In Figure 3, the interface between the TX/RX elements and MC (to form an RFMC) and the RFpads is illustrated: TXs/RXs are assumed to be present on each RFMC and rank, and upon a cache request, signals go through the RFMC TX

where they are converted to analog waves. Next they traverse the waveguide/CPW and reach RX, where analog waves are converted back to digital signals in order to reach the busses and a rank. The signal does traverse the same path in the opposite direction when a rank responds, and at the RFMC-RX it is converted down back to digital before reaching the processor.

D. *RFiop* Viability

RFiop viability relies on QP lines. The fact that QP was prototyped and tested for BW up to 60GHz, whilst presenting low-magnitude return loss (0.1dB), demonstrates the viability of RFpads. Moreover, being simulated for BW up to 200GHz, QP lines reduce the number of pads, which is aligned to the pad reduction goals.

In general, RF design explores the matureness achieved in CMOS manufacturing, and is therefore a very consolidated technology. Once putting chips down and sliding to match each other is a straightforward process according to [15], QP lines are reported to be manufacturable through the programmability of already-existing industry tools such as pattern-recognition of the modules. Self-alignment structures are easily built into the shapes of the nodules as indicated in [15]. Deep reactive ion etching (DRIE) can be used to separate chips from wafers.

E. *RFiop* Limitations and Approaches to address them

The following approaches address the previously mentioned *RFiop* limitations:

- The manufacturing technology evolution is likely to allow a reduction of twice the area used by the cores, thus likely allowing more ranks to be fit, which enables a large core:package area ratio.
- Other than using QP as RF-interconnection lines in *RFiop*, microstrips and striplines could be potentially employed [12] thus allowing other benefits such as lowering costs, improving data rates, and/or reducing losses.

IV. EXPERIMENTAL SECTION

Bandwidth, latency, number of pads, energy, area and temperature are the key technical elements which help the researcher understand the goals and achievements of *RFiop*. To evaluate these *RFiop* elements, an experimental infrastructure composed by Mathematical modeling and several detailed-accurate simulators is employed as follows:

- Determination of QP RF BW ranges needed to match memory data rates to minimize the number of RFpads.
- To the best of our knowledge, it is the first time that a Mathematical modeling for IL , RL and CN is obtained via regression from the resulting RF-behavioural simulations performed by Liu [15].
- Mathematical pad scaling modeling to determine the behaviour of the number of RFpads as a function of the rank data rates and width.
- M5 simulator [18] to simulate the multicore system running bandwidth-bound applications.
- DRAMsim simulator [17] to simulate *RFiop* multiple MCs with RF settings. DRAMsim receives transaction

requests generated by the M5 simulator. After having simulated these transactions, DRAMsim returns the answers of the requests to M5. Rank power statistics are collected from DRAMsim and/or Micron power sheet [2].

- Cacti [23] cache simulator to determine cache latencies to be used in M5 multicore simulation.
- McPAT [24] simulator collects architectural results from M5 and determines the amount of area and power used by different components of an RFMC.
- Derive power modeling for the RF-based memory channel based on the Mathematical modeling developed in [14].
- Temperature simulation [25] to determine the behaviour of *RFiop* memory organization.

The first three steps previously proposed guide the RFpads behavioural modeling in terms of RF behaviour and scaling. The remaining steps allow to extract performance, power and temperature implications of *RFiop*.

A. Determination of RF frequency ranges to match memory data rates

In the first order, bandwidth provided by each rank dictates the number of lines required: not considering loss effects, the ratio between rank bandwidth and RFpad RF-bandwidth determines the amount of RFpads needed to match rank data rate.

To show the benefits of an RF-based memory path, once QP was manufactured and has validated RF-properties, QP lines/parameters are employed as the RF-interconnection lines between RFMCs/ranks in *RFiop* without any loss in generality.

To determine the number of RFpads (RFpad counts), the number of QP lines is required: the key is to match QP data rate to the rank data rate. QP data rates are estimated with on-chip RF scaling predictions by F. Chang et al. [12] (Table Ib). Though valid for on-chip interconnections, these are also considered valid when connecting two different dies via QP. A second reason to justify this strategy is the significantly reduced inter-die distance in QP (around 40 μ m), completely within on-chip typical distance ranges. RFpad count determination is performed under three strategies: (i) considering simulated QP *BW* (200GHz [15]), (ii) validated QP *BW* (60GHz [15]), and (iii) taking into account just RF predictions (half of maximum CMOS frequency carrier in table I[3][12]) i.e., regardless of the assumption of QP as RFpads.

In strategy (i), design and estimation of RFpads counts employ the rank previously used in Section II. 32nm-technology is assumed - in Table Ib; it allows 12 carriers and data rate per carrier of 8Gbits/s. With a static RF band allocation [12] these carriers are spaced by 32GHz to avoid crosstalk (further described) that could lead to low bit error rate (BER). Using QP *BW* as 200GHz[15] and previous carrier spacing, there are up to 6 carriers, each with 8Gbits/s of data rate, thus the overall data rate budget available for each RFMC is 48 Gbits/s. Next, important *RL*, *IL* and *CN* parameters are determined.

B. Determination of Return Loss (*RL*), Insertion Loss (*IL*) and Crosstalk Noise (*CN*) for RFpads

As mentioned in Section II-D, Liu [15] has performed a wide range of simulations using Ansoft HFSS 3D electromagnetic field solver simulator [20] in order to determine *RL*(*S*₁₁), *IL*(*S*₂₁) and *CN* behaviour of the RFpads. In these simulations, different RFpad widths and different silicon resistivity substrate for a wide range of frequencies were utilized. To exemplify, the widths (100 μ m, 50 μ m, 20 μ m and 10 μ m), and two different silicon resistivity substrates (high, which means a magnitude resistivity of 8000 Ω .cm and low, which means a resistivity magnitude of 10 Ω .cm) as well as *BW* from 0 to 40GHz for (100 μ m- and 50 μ m-width) and from 0 to 200GHz for (20 μ m- and 10 μ m-width) were simulated.

Output magnitudes of these previously simulated losses for the 20 μ m-width RFpad are illustrated in Figure 4a. In this example *IL* is lower than -5dB, *RL* stays between -20 and -40dB and *CN* between -60 and -10dB. If such losses are not acceptable, it is a designer's task to tackle them, such as having larger separation gaps between them or augmenting the number RFpads.

In order to incorporate the behaviour of the RF circuits in the RFpads *RL*, *IL* and *CN* parameters are proposed to be represented via an extensive least square quadratic polynomial regression over the wide range of *IL*, *RL* and *CN* simulations performed in [15] in order to determine their Mathematical behaviours as a function of frequency ranges within *BW*. Without any loss in generality, given simulated *BW* magnitudes of 200GHz, the 20 μ m-width range and high resistivity are conservatively adopted. As a result of this regression, the following formulations are obtained:

$$\begin{aligned}
 RLH(f) &= 2.573988065 * 10^{-16} * f^9 - 2.22139361 * 10^{-13} * f^8 + \\
 &= 8.020049855 * 10^{-11} * f^7 - 1.576525975 * 10^{-8} * f^6 + \\
 &= 1.843388408 * 10^{-6} * f^5 - 1.320228749 * 10^{-4} * f^4 + \\
 &= 5.797660813 * 10^{-3} * f^3 - 1.566649281 * 10^{-1} * f^2 + \\
 &= 2.882054915 * f - 59.96827969
 \end{aligned} \tag{18}$$

$$\begin{aligned}
 ILH(f) &= 2.459007338 * 10^{-19} * f^{10} - 2.469419009 * 10^{-16} * f^9 + \\
 &= 1.062082119 * 10^{-13} * f^8 - 2.556564595 * 10^{-11} * f^7 + \\
 &= 3.777876047 * 10^{-9} * f^6 - 3.538827666 * 10^{-7} * f^5 + \\
 &= 2.098085852 * 10^{-5} * f^4 - 7.660830361 * 10^{-4} * f^3 + \\
 &= 1.64219124 * 10^{-2} * f^2 - 1.995163588 * 10^{-1} * f - \\
 &= 2.526135981 * 10^{-1}
 \end{aligned} \tag{19}$$

$$\begin{aligned}
 CNH(f) &= s_{13} = -1.567317848 * 10^{-18} * f^{10} + \\
 &= 1.678387101 * 10^{-15} * f^9 - 7.774761181 * 10^{-13} * f^8 + \\
 &= 2.039691044 * 10^{-10} * f^7 - 3.330113718 * 10^{-8} * f^6 + \\
 &= 3.49673987 * 10^{-6} * f^5 - 2.355209243 * 10^{-4} * f^4 + \\
 &= 9.886149607 * 10^{-3} * f^3 - 2.484417801 * 10^{-1} * f^2 + \\
 &= 3.633086388 * f - 47.08822923
 \end{aligned} \tag{20}$$

where *RLH* means return loss, *ILH* means insertion loss

and CNH means crosstalk noise, all at high resistivity. By performing the previous regression, it is guaranteed that RL , IL and CN follow the simulations performed, i.e., to include RF behavioural details in the RFpads. Given the above equations, the designer can determine the behaviour of such important RF parameters (IL , RL and CN) for future memory data rates. Other equations such as return loss (RLL), insertion loss (ILL) or crosstalk noise at low resistivity (CNL or $s13$), can be similarly obtained and are omitted due to lack of space.

C. Determination of the Number of RFpads

For subsequent modeling, memory read/write operations are assumed, while utilizing RFpad modeling equations (from equation 21 to 27 developed in Marino's report [16]).

RF-delays through TX/RX are not included in the following formulations due to their insignificant magnitudes (around 200-picosecond range [12]) compared to the duration of memory timing operations. To determine RFpad count behaviour, $memory_bits$ or mb is defined as:

$$mb = mc * dr \quad (21)$$

i.e., a function of the number of bits transmitted in one memory cycle - mc , where dr is the memory $data_rate$. $RFiop$ total cycle (tot_cycle) is limited by the maximum BW allowed in QP (200 GHz [15] as QP is adopted). Keeping DRAM circuitry as original as possible, dedicated RF-interconnection lines (control and data) for RFpads are included:

$$RFpads = number\ of\ RFpads\ per\ RFMC \quad (22)$$

$$RFpads_data = floor(data_mb/(mc * mb)) \quad (23)$$

$$RFpads_data = floor(data_mb/(mc * drRFc * nRFc)) \quad (24)$$

Considering respectively $RFpaddr$, $RFpads_data$, $RFpads_ct$, $drRFc$, $nRFc$ as the total RFpad data rate, number of RFpads destined for data/control lines, data rate carriers, and number of RF carriers, the following equations can be utilized:

$$RFiopaddr = \sum nRFc * drRFc, \quad (25)$$

$$RFpads_ct = floor(ct_mb/(mc * drRFc * nRFc)) \quad (26)$$

$$RFpads = RFline_data + RFline_ct \quad (27)$$

Having inspected ranks with similar features in Micron catalogs [2], except voltage, ground, and not-connected pins, around 123 bits are used in one rank access (total of 240 pins, around 50%; 64 for data, and 59 for control). Assuming the same rank (1GB-DIMM DDR3 rank, with 64-data-bit, 1333 MT/s-data-rate, based on Micron MT41K128M8[2]) previously employed in the bandwidth characterization (Section II-A), from equations (5,6) the total amount of bits (tot_bits) transferred via one RFpad in one memory clock (1/1333MT/s) is:

$$tot_bits = (1/1333/s) * 6carriers * 8Gbits/s; \quad (28)$$

$$floor(tot_bits) = 36bits, \quad (29)$$

Therefore, in one memory cycle only 4 RFpads are needed to perform an RF transfer of 144 bits, which carry the total of

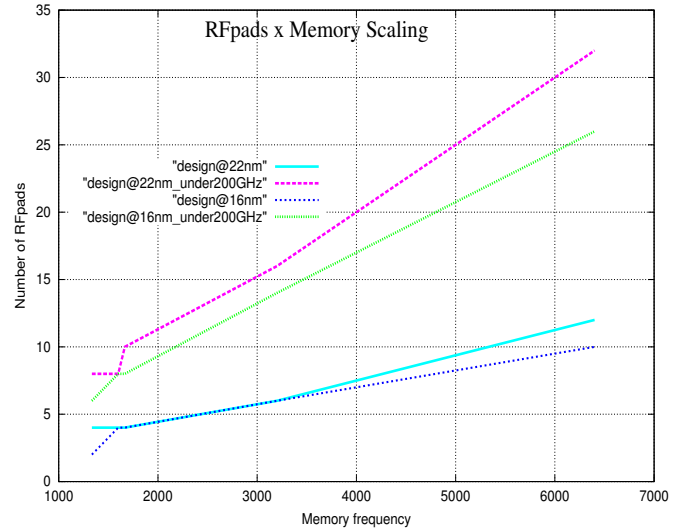
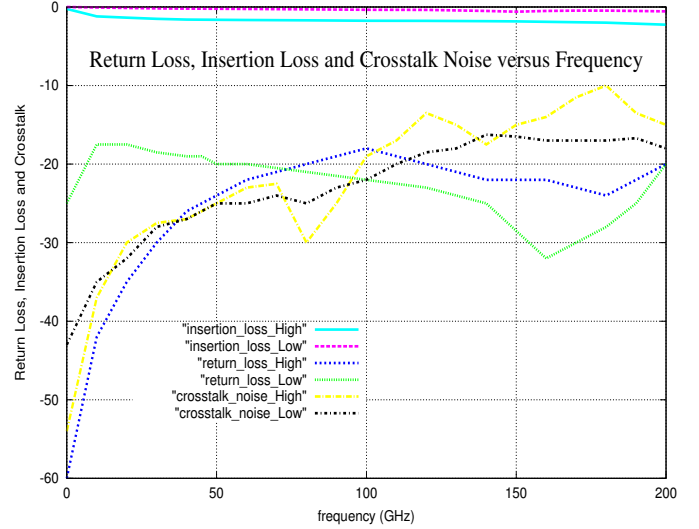

Fig. 4: top to bottom: (a) return loss (RL), insertion loss(IL) and crosstalk noise (CN) for high and low resistivity versus BW ; (b) RFpad and memory data rates.

123 memory bits (64 of data plus 59 of control). Other widths can be used via recalculation of equations starting from 21.

According to Chang et. al [12], to avoid IL , RL and CN previously observed effects and minimize likely BER, as a general rule-of-thumb RFpads are doubled. Following this rule, 8 RFpads are required to transfer 64-data and 59-control bits.

Very importantly, Figure 4b shows related experiments performed in the initial $RFiop$ report [16]. Comparing Figures 4a and 4b, either with faster DDR3 memories (1333MT/s versus 666MT/s in the initial $RFiop$ report) or DDR4/DDR5 models, RFpads still scale properly, enabling RFMC scaling.

By comparing RFpad scalability to current DDR-based pad counts, assuming a pad:pin ratio of 1:1 and 200-GHz- BW (QP parameters[15]), it is concluded that $RFiop$ has 4x more MC pads (8 RFpads) than optical-Corona [10], a MC pad reduction of 4x when compared to RAMBUS XDR2, and up to 6x when compared to FBDIMM.

Before comparing $RFiop$ to HMC[7], a brief background

about HMC is presented. A HMC rank is composed of a single package containing multiple memory dies which form one logic die. A vault is defined as a set of banks of memory dies, and different vaults are going to contain different memory die portions. Each vault has a MC named vault controller (VC) which is responsible for managing its memory references to that specific vault, besides timing, refresh operations, and buffering vault accesses. As opposed to HMC, *RFiop* follows typical DDR organization in ranks (rows, columns, and banks) as multiple dies placed on a coplanar layout (Figure 1).

In HMC, the communication between memory die and processor happens via serial/deserial communication over I/O-links, while *RFiop* employs modulation over QP lines. Typical I/O-links in HMC present 10Gbit/s versus 48Gbit/s-links (6 carriers, 8Gbit/s data rate) in *RFiop*. The maximum aggregated bandwidth in HMC is 320GB/s, which is significantly higher than in *RFiop*, i.e., with memory settings defined in section II.A, *RFiop* maximum bandwidth achieves 96 GB/s (16RFMCs x 6GB/s). However, to have *RFiop* achieving the same levels of bandwidth of HMC the improvement of transistor technology is likely to allow (i) a larger number of RFMCs (1:1 RFMC:rank assumption); (ii) QP *BW* is likely to increase. Assuming that at 22nm, 32 ranks can be fit in (i) *RFiop* package area, *RFiop* memory bandwidth is leveraged to 192GB/s. (ii) With the assumption that the QP *BW* is doubled, about double the carriers can be fit whilst larger data rates are allowed (10Gbit/s) thus resulting in 480GB/s, which is much larger than 320GB/s in HMC.

Alternatively, if the number of pads is not considered, having the 55 pins of HMC (versus 4RFpads in *RFiop*) as budget in *RFiop* allows 1056GB/s (55 over 4 = 11; 96GB/s * 11 = 1056), i.e., 3x more bandwidth than HMC. Further advancing *RFiop* report[16], assuming a pad:pin ratio of 1:2 (at the beginning of this subsection) and that a HMC memory package utilizes 8 links correspondent to 8 VCs and 55 I/O-pins, in *RFiop* the equivalent configuration with 8 RFMCs - each RFMC corresponding to one VC - is likely to have 32 RFpads, i.e., a much lower pad usage than HMC.

To predict future memory data rate versus RFpads scaling behaviour (which is supported by the scaling of RF technology, number of carriers and *BW*) different types of faster memories (e.g. DDR4/DDR5) are similarly modeled (via equations 4/6) (i) with and (ii) without a *BW* limit of 200GHz (QP [15]) and using 16nm-/22nm-RF-technology based on RF ITRS predictions [3][12]. The result of this modeling is shown in Figure 4b, which demonstrates RFpad scalability along future memory and RF interconnection generations.

On strategy (ii) (defined at Subsection IV-C) as assumed in *RFiop* report [16], a combination of QP prototyped/validated *BW* of 60 GHz [15] with the pad reductions obtained (30% in RAMBUS XDR2 and 50% in Intel FBDIMM), it is found that, if compared to HMC, *RFiop* can reduce the number of pads up to about 56%.

Moreover, regarding strategy (iii) which was defined at Subsection IV-C, assuming RF predictions [3][12] and disregarding

tech	MC I/O pad count	bandwidth per pin (Gbits/s/pin)	intercon. energy per pin	mem energy (pJ/bit)
GDDR5	120	2.5	-	250
DDR3 1600	120	1.6	8	160
DDR4/DDR5	120	5	-	250
Intel FBDIMM	48	2.5	-	-
RAMBUS XDR2	32	12.8	-	50
HMC	55	10.0	-	100 [7]
Optical Corona	2	640	0.078	-
DIMM Tree	39	8	2.5-4	-
<i>RFiop</i>	8	6-12	0.6-0.7	87

TABLE II: different memory systems comparison: number of I/O pads, memory bandwidth per pin, interconnection energy, and memory energy [2][6][8][10][12][26]

QP parameters, remarkable 4RFpads are found as reported in [16], which are of similar magnitude to optical-Corona [10].

Table II compares pad-count, bandwidth-per-pin, interconnection energy, and energy among diverse systems, including *RFiop*. Other energy aspects are discussed in subsection IV-I.

Comparing modeling equations 22-27 to the ones previously developed in [16]:

- equations 21-27 are valid for different types: different data rates and/or widths than 8 bytes (DDR standard).
- equations 21-27 can be used to determine different pad counts as a function of scaling widths.

Next, different memory types/technology and RFpad counts scalings are compared using the developed modeling.

D. RFpad area. Die area saving and I/O pad reduction

Liu's design space exploration [15] of QP dimensions results in 20 μ m-to-100 μ m and 10 μ m respectively for depth and width. Since QP lines are RFpads, previously obtained dimensions are valid for RFpads. Using these results, Marino [16] reports RFpad dimensions of 200 μ m² to 1000 μ m². Once the insertion of ground lines is the typical rule of thumb to minimize crosstalk between two adjacent lines, RFpad pitch is conservatively assumed as the largest dimension of QP, i.e., around 100 μ m.

Being RFpads (QP lines) built at the side of the die, i.e. not at the basis, they favour I/O pad die area saving [21]. To further estimate area savings, an ITRS 1023-pad limitation is assumed as illustrated in Figure 2. In this assumption, 50% (512 pads, rounded 50% of 1023) are dedicated to data/control bits (the remaining 50% to power and other e.g. I/O and interrupt) [21].

Thus, for a typical DDR3 240-pin budget and area estimation of 50%, 46.9% (240/512) of the die area allocated to the I/O

pads can be potentially saved [21]. Furthermore, since I/O pads are connected to the same set of I/O pins, a significant reduction is expected in the latter[21]. A comparative area analysis between RFMC and traditional MC is performed in Subsection IV-H. Next, temperature comparison with 3DStacking is approached.

E. Temperature Comparison: *RFiop* and 3Dstacking

In this subsection temperature effects are compared in *RFiop* and 3Dstacking when scaling ranks. Both architectures are assumed to have: (i) 256 μm^2 for rank area based on 3Dstacking rank dimensions [1] once 3Dstacking is an on-package/on-die technology; (ii) initial rank temperatures at the same magnitude of the L2 caches (assumed as 60 degree Celsius).

(iii) Hotspot tool [25] with its respective gcc benchmark trace is used to compare both architectures. (iv) Most parameters employed in this estimation are the default ones used in the Hotspot tool configuration file [25], except the area covered by the heat sink and spreader, which is conservatively adjusted to a maximum of 0.05m in either configurations.

(iv) The number of ranks was scaled up to 16, either in *RFiop*/3Dstacking to match the maximum number of RFMCs/MCs. As a result of this temperature modeling, *RFiop* is about 10.5% lower than 3Dstacking, thus likely to be advantageous when scaling of ranks/RFMCs.

F. Performance Evaluation Methodology

RFiop is modeled using M5 [18] and DRAMsim [17] simulators. Memory transactions are generated by M5 and captured by multiple MCs/RFMCs in DRAMsim, which responds to M5 with the result of the memory transaction. To have enough memory pressure and demonstrate higher bandwidth under RFMC scalability, a clustered microprocessor architecture with 32 cores is selected - previously explained in the motivation section - versus 16 cores in previous *RFiop* report [16]. Furthermore, to ensure higher memory pressure OOO-processors (based on Alpha, 4-wide issue, similar as in [16]) have been employed with private L2 slices to prevent cache sharing from affecting bandwidth. Furthermore, a banked-scalable L2 MSHR structure is assumed with 1MB/core L2 slice size [27]. L2 slices communicate through an 1-cycle RF-crossbar, i.e., similar RF-circuitry latency settings adopted by F. Chang et al. [12]: 200ps of TX-RX delay, plus the rest of the cycle to transfer 64 Bytes via high speed/modulation, which also prevents larger interconnection delays from masking memory settings. Instead of bus delays, RF TX-RX delays were also configured in DRAMsim to represent RF transmission.

Based on the rank previously used in Section II (Micron MT41K128M8 [2], parameters in Table IIIb are kept constant throughout all experiments). To generalize *RFiop* usage with different DDR-families, different rank parameter settings from [16] are used, particularly with the 1333MT/s-memory data rate instead of the 666MT/s.

In all experiments, as stated in Section II-A, to avoid no advantage is taken on locality, [17] addresses are equally distributed along the ranks, via cache-address interleaving along

Core	4.0 GHz, OOO-Core, 4-wide issue, tournament branch predictor
technology	32nm
L1 cache	32kB dcache + 32 kB icache; associativity = 2 MSHR = 8, latency = 0.25 ns
L2 cache	1MB/per core ; associativity = 8 MSHR = 16; latency = 2.0 ns
RF crossbar	latency = 1 cycle
RFMC	1 to 16 RFMC; 1 MC/core, 2.0GHz, on-chip buffer size = 32/MC, close page mode
Memory rank	DDR3, 1 rank/MC, data rate: 1333MT/s, 64bits 1GB, 8 banks, 16384 rows, 1024 columns Micron MT41K128M8 [2] tras=26.7cycles, tcas=trcd=8cycles
Latency from	1 cycle to transfer commands or one data burst

Benchmark	Input Size	read : write	MPKI
Add,Copy,Scale,Triad(STREAM)	4Mdoubles per core;2iter	2.54:1	54.3
pChase	64MB/thread,3iter,random	158:1	116.7
Hotspot(Rodinia)	6000x6000,3iter	2.5:1	12.5
CG: Conjugate Gradient(NPB)	ClassA,3iter	76:1	16.9
MG: Multigrid(NPB)	ClassA,3iter	76:1	16.9
SP: Scalar Pentadiagonal(NPB)	ClassA,2iter	1.9:1	11.1
FT: Fourier Transform(NPB)	ClassW,3iter	1.3:1	6.8

TABLE III: top: (a) Parameters of the modeled architecture; bottom: (b) benchmarks configuration.

RFMCs and closed page mode (server). Using previous RF assumptions, a 200ps-TX/RX-delay[12] is estimated. Due to the speed-of-light property of RF, signal delays of commands-duration and burst-duration between RFMC/rank are estimated to be reduced from two cycles to one cycle and from eight cycles (typical) to one cycle[2]. DRAMsim was modified to support an arbitrary number of RFMCs. In DRAMsim, each RFMC has a FIFO associated to queue memory requests, as well as duration and occupation of the banks and taking all of these into consideration contention is properly modeled. To evaluate RFMC scalability, core:MC proportion is varied from the baseline configuration 32:5 up to 32:16 (32 cores, 16 RFMCs, as previously justified) via M5/DRAMsim simulations with a different number of RFMCs. In Figures 5a and 5b, the baseline core:MC ratio of 32:5 is shown as a matter of reference - 5MCs (Section II-A).

To obtain cache latencies, Cacti[23] is set with aggressive ultra low-power optimizations. MSHR counts selected for each L2 slice follow the study by Loh[1] once multiple MCs and ranks as OOO-cores are used in it. Summarizing, all parameters used in the simulation environment are in Table IIIa.

Benchmarks have been selected according to Loh's[1] criteria, focusing on the ones with a high number of misses per kiloinstructions (MPKI) to exercise the memory system. The selection involves (i) STREAM[19] suite to evaluate bandwidth, decomposed in its four sub-benchmarks (Copy, Add, Scale, and Triad); (ii) pChase[28] designed to evaluate bandwidth and latency, with pointer-chase sequences randomly accessed; (iii)

Hotspot from Rodinia suite[29]; (iv) Conjugate Gradient (CG), Scalar Pentadiagonal (SP) and Fourier Transform (FT), from NPB as part of the HPC challenge to evaluate bandwidth[30]. STREAM and pChase bandwidth measurements are extracted from these applications since these are designed to measure bandwidth. Table IIIb shows the benchmarks, input sizes, read-to-write rate, and L2 MPKI obtained. In all benchmarks, parallel regions of interest are executed until completion. Input sizes are large enough to stress the memory system (120MB to 1.8GB). Average results are calculated using harmonic average. For the rest of this evaluation, the following are defined:

- baseline: as determined in section II, corresponding to the electrical counterpart version with 5 MCs (Section 2), which are constrained to I/O pin scalability.
- *RFiop*: represents *RFiop* with RFMC scalability benefits, i.e., with RFMCs scaling up to 16 RFMCs and 16 ranks.
- To facilitate comparison, the terms *RFiopa*, *RFiopa_burst_command* and *RFiopa_burst_command* are adopted from Marino’s report[16]. *RFiopa* is defined as the RF version with the same area budget as the baseline to explore its architectural benefits in terms of higher RFMC counts. As further described in Section IV-H, *RFiopa* can have up to 12 RFMCs. *RFiopa* magnitudes were not directly obtained from the simulators, but extrapolated from the performance results.
- *RFiop_burst_command*: *RFiop* plus (simultaneously) RF latency benefits (on command/burst transfers).
- *RFiopa_burst_command*: *RFiopa* plus RF latency benefits applied to command and burst transfers.
- *RFiopp*: as the version that uses MC power as power budget, based on further power/energy analysis (Subsection IV-I1), *RFiopp* can have up to 16 RFMCs. *RFiopp* has bandwidth/speedup behaviour similar to *RFiop*.

G. Bandwidth, Latency, Speedups and Number of cores: Sensitive Analysis

Bandwidth benefits from RFMC scalability are analysed first, and next high-speed signaling. In Figure 5a, the bandwidth obtained for different core:MC ratios (32:5, 32:8, 32:12 and 32:16), and with STREAM and pChase, respectively representing stream and random behaviours is improved with the increase of the number of RFMCs. Significantly, *RFiop/RFiopa* respectively provide 3.6x and 2.6x more bandwidth than the baseline due to larger RFMC counts (larger memory parallelism). Comparing Figures 5a and 6, bandwidths are up to 10% larger due to the use of larger data rate memories. Moreover, RFMC scalability does provide bandwidth growth with different memory settings and any number of RFMCs, which generalizes and validates *RFiop* RFMC scaling previously proposed[16].

Speedups obtained for different core:MC ratio (32:5, 32:8, 32:12, and 32:16), i.e. with different RFMC counts, are shown in Figure 5b. For all benchmarks, speedups increase proportionally to the increase of the number of RFMCs. Compared to the baseline, for STREAM benchmark *RFiop* and *RFiopa* are 4x and 3x significantly faster. Similar significant scaling

trends are obtained of 2.4x for pChase, 3x for Hotspot, 2.3x faster for CG, 2.2x for FFT, 2.7 for SP, and 2.5x for MG. The largest bandwidth and speedup improvements occur for STREAM and pChase due to their large MPKI magnitudes (Table IIIb). Significant results using this variety of bandwidth-bound benchmarks demonstrate the generality of the solution.

Considering RFMC scalability, pChase bandwidth and latency present improvements of 4%-25.8% and 10%, whilst speedups improve up to 3x (transaction queue average duration/occupancy reduction). Combining RFMC scalability and high-speed, overall speedups have shown a significant improvement of up to 4.3x, whilst *RFiopa* achieved a significant factor of 3.2x when compared to the baseline. Alternatively, the latency in Figure 8 follows a similar reduction trend when considering high-speed RF benefits.

RFiopa (*RFiop* under area budget constraints) presents similar behaviour trends to *RFiop* for bandwidth, speedups, and latency. Therefore, performance and energy benefits can be observed when architectural area benefits of RFMCs replacing traditional MCs (*RFiopa* definition) are considered.

Similarly to *RFiopa*, architectural power budget is explored by replacing traditional MCs with RFMCs in *RFiopp*. Architectural area (Section IV-H) and power (Section IV-I) analyses show that a larger number of RFMCs can be used in *RFiopp* (16 RFMCs) than in *RFiopa* (12 RFMCs). This demonstrates that the area factor considered in *RFiopa* is more restrictive than the power factor considered in *RFiopp*, whilst bandwidths and speedups are achieved in both.

Whilst some benchmarks exhibit RFMC scalability limitation (observed saturation on the bandwidth/speedup curves), considering that memory requests are equally interleaved over RFMCs and cache transfers are done in one cycle (RF-crossbar latency), a deeper investigation of simulators statistics shows significantly different L2 miss rates in some slices, which provides evidence of the churn phenomenon reported by Loh [1] when scaling MSHRs, not necessarily decreasing L2 miss rates, that is left as a further investigation [16]. Moreover, Figure 5b presents speedups 10% higher than in Figure 6, thus demonstrating that benefits provided by a larger number of RFMCs are also valid for different benchmarks. A sensitivity analysis of the number of cores and latency is performed next.

1) *Number of Cores*: More cores in the experiments shown in Figure 5 (32 cores) than in previously published results shown in Figure 6 (16 cores) illustrate that higher MC counts improve bandwidths/speedups in *RFiop/RFiopa* up to 20%.

2) *Latency*: Larger RFMC availability results on shallower transaction queues and smaller transaction duration. Due to lack of space, latency results are only shown for STREAM and pChase. To the right of Figure 5a, by increasing RFMCs for both *RFiop* and *RFiopa*, occupancy is reduced of up to 3.0x and 2.0x (STREAM/pChase) when compared to the baseline. Furthermore, Figure 8 shows that the average duration of memory accesses is decreased by up to 3.5x/2.2x for *RFiop/RFiopa*. This can also be seen in pChase, where latency is significantly reduced of 61% when compared to the baseline.

Comparing obtained latencies in the previous report[16] and

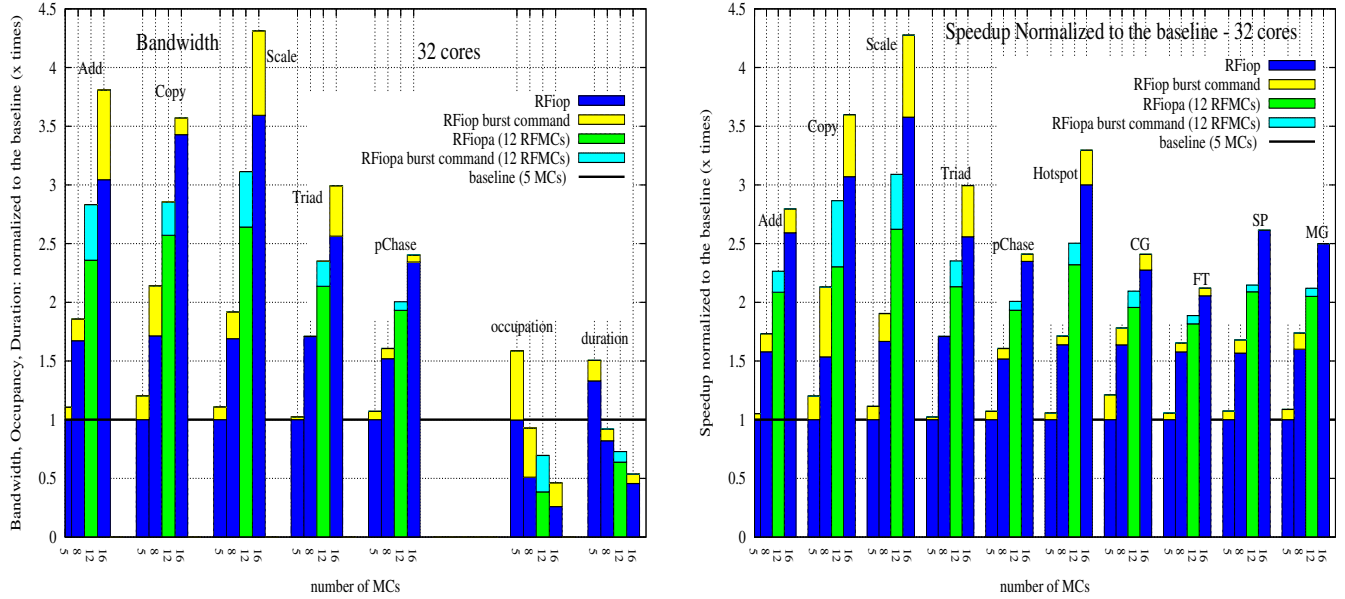

Fig. 5: 32 cores; left to right (a): bandwidth, tr. queue occupancy/duration; (b): speedups; baseline: I/O pad constraints; *RFiop*: RFMCs/RFpads; *RFiopa*/*RFiopp*: *RFiop* under area/power budget; *RFiopa*/*p_burst_commands*: plus RF latency benefits

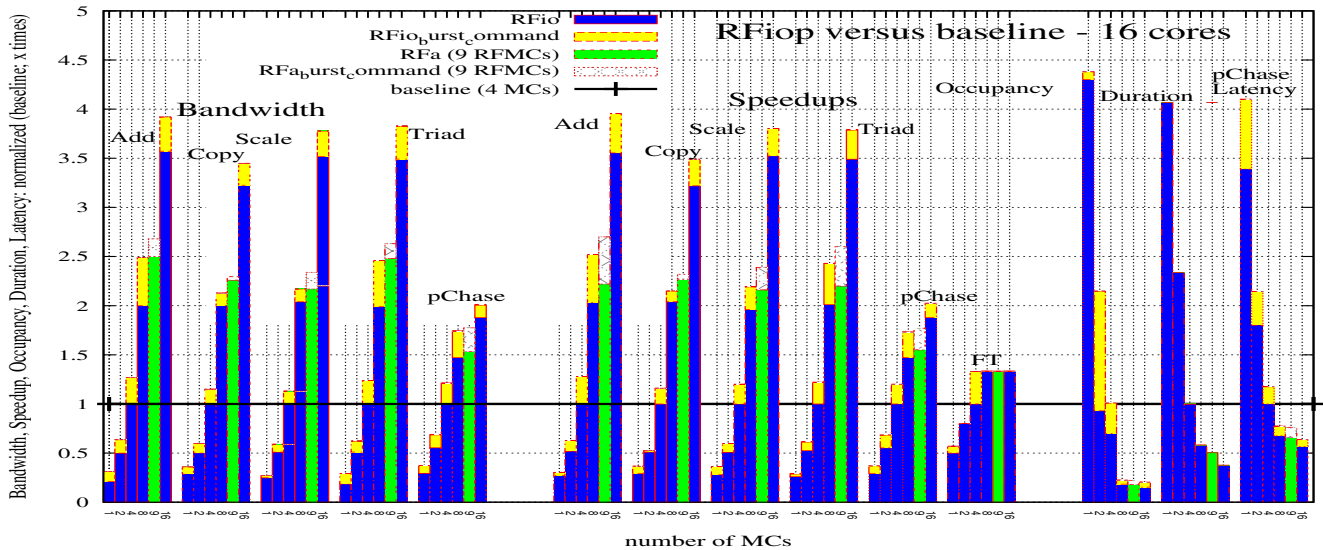

Fig. 6: *RFiop*, 16 cores from [16]; Left: bandwidth, tr. queue occup/duration; right: speedups; baseline: I/O pad constraint; *RFiop*: RFMCs/RFpads; *RFiopa*: *RFiop* under area budget; *RFiopa*/*RFiopa_burst_commands*; *RFiopp*/*RFiop* plus RF latency benefits

those shown in Figure 8, a surprisingly remarkable latency reduction of 30% is obtained. Even when using twice as fast memories, RFMC scalability can further reduce latencies under the pressure of twice the number of cores generating memory traffic. Compared to the previous experiments in Figure 6 where 666MT/s-memories were used, occupancy and duration are lower in Figure 5a with 1333MT/s-memories.

H. RFMC versus MC area

First TX/RX area is estimated and after that, the impact of this area is determined for different technology generations. To estimate TX/RX area, a similar methodology (further described in Subsection IV-II) is adopted from Tam *et al.* in [14] as a

combination of RF circuitry area estimations from ITRS[3], design of TX/RX circuitry[12] and validated TX/RX circuits [31]. As a result, TX/RX area is estimated at about 0.0123-0.015 mm², which is of lower overhead.

MC internal elements are introduced to highlight the differences between an RFMC and a typical MC: in either, (i) the front engine (FE), that processes requests from memory; (ii) the transaction engine (TE), that transforms memory requests into control/memory commands; (iii) the physical transmission (PHY), which is constituted by control and data over traditional physical channels[24] at MCs versus RF TX/RX and RF channels at RFMCs.

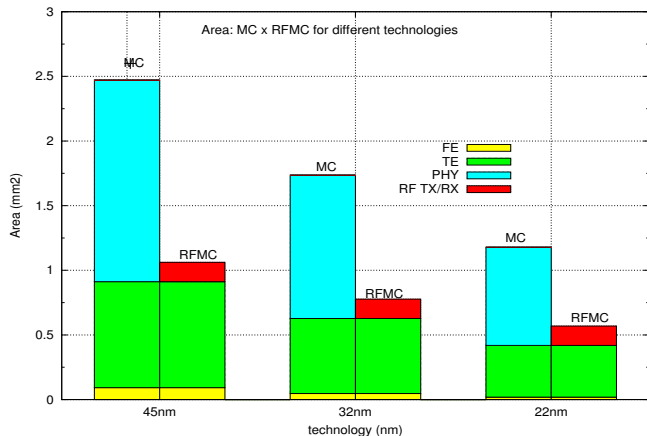

Fig. 7: RFMC area saving

McPAT[24] tool estimates area and power of FE/TE/PHY parts of a regular MC. Since FE and TE are both present in MC/RFMC, by using an average over the previous simulated benchmarks in McPAT as well as specific *RFiop* settings (methodology further described in Subsection IV-I1), the area occupied by FE/TE is determined whilst RF RX/TX area are obtained as previously described.

Similar to Marino’s report[16], in Figure 7 it is observed that PHY is the dominant element in terms of area; for different technology generations, 57.3% of MC area can be saved when replacing MCs by RFMCs. Put differently, by adopting MC area as area budget, up to 2.4x more RFMCs can be fit on the die, i.e. up to 12 RFMCs (versus 5MCs-baseline area budget).

I. Power and Energy Analyses

The following analyses aim to identify and compare power/energy magnitudes of *RFiop* with its respective traditional counterpart: RFPad interconnection and total rank energies.

1) *RFPad interconnection energy*: As previously analysed in Subsection IV-H, FE/TE are either present in RFMC or MC and, as previously adopted, McPAT is used to estimate the power of both these parts. However, since the PHY is the most significant element in terms of power when compared to FE and TE, its power and amount of bits transferred to/from memory are included as part of the dynamic energy.

According to the methodologies [8][10][26], energy is preferable rather than power since the former considers the amount of bits transferred with the memory. For a traditional MC, PHY contains I/O pins and a regular channel, which power can be estimated by McPAT[24]. However, for RFMC, PHY is represented by RF TX/RX and RF interconnection, i.e., I/O pin and line power is replaced with TX/RX and RF line power.

Similarly to the previous RF TX/RF area estimation in Subsection IV-H, power estimation relies on a combination of RF circuitry estimations from ITRS[3], design of TX/RX circuitry[12], and validated TX/RX circuits [31], all adjusted to *RFiop* settings: (i) an average distance of about 1mm from each RFMC to its respective rank RX/TX is assumed ; (ii) since

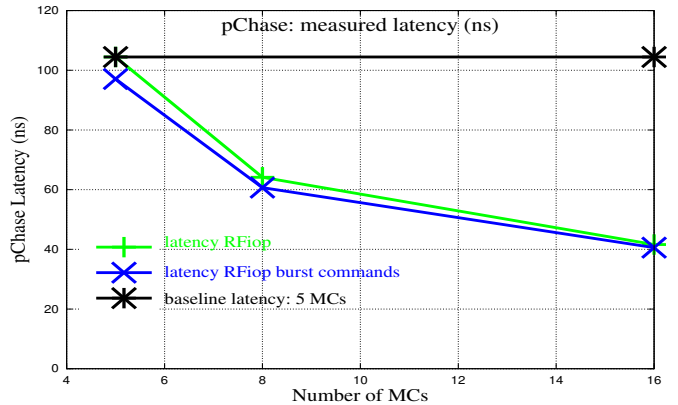

Fig. 8: pChase measured latencies

QP *RL* is of significantly reduced magnitude [15], and TX/RXs elements designed for QP are still an open area, a conservative power reduction - estimated in 10% - can be applied to the employed transmission models[12][14].

Moreover, since energy-per-bit depends on bandwidth, its modeling is performed considering an average of the simulations performed previously (Subsections IV-F and IV-G), which includes their memory utilization. Figure 9a illustrates the results of energy modeling in which different distances and different technologies (45, 32, and 22nm) are experimented for RF versus traditional ones. Given distances assumed, RF can save an average of 78% of PHY energy if compared to the baseline. This power budget reduction allows the significant factor of 4.6x more RFMCs to be fit in the package area, i.e. a total of 23 RFMCs (5 x 4.6), conservatively rounded to 16 RFMCs (maximum of 16 RFMCs as previously stated [16]).

2) *Total Rank Energy*: In this work *RFiop* is set with traditional DDR3-1333MT/s ranks (detailed in Table IIIa), mainly focusing on the memory channel reduction, rather than on rank power reduction. Despite this, it is also shown that TX/RX utilization at the rank can reduce power which can be estimated by employing Micron power sheet [2], whilst previously assumed RF models [12][14] are employed to estimate RF TX/RX power. Therefore I/O pin termination power is replaced with TX/RX power in *RFiop*: this results in a 6.7% power reduction of DRAM power.

In order to determine the total rank energy-per-bit (*repb*) usage when using multiple memory channels and ranks attached to them, the following calculation is performed:

$$repb = total\ power / total\ bandwidth \quad (30)$$

Total rank energy considers dynamic and static power spent by all ranks: it is obtained via Micron data sheet [2] combined with the set formed by M5 generating memory requests when running the benchmarks and DRAMsim[17] (responding to M5 and performing accounting of memory accesses, managing contention and others). Obtained results show that static power is roughly 10% of the dynamic one. Bandwidth is obtained via similar experiments and settings performed in Section II (different RFMC/MC counts).

Energy experimentation results are shown in Figure 9b.

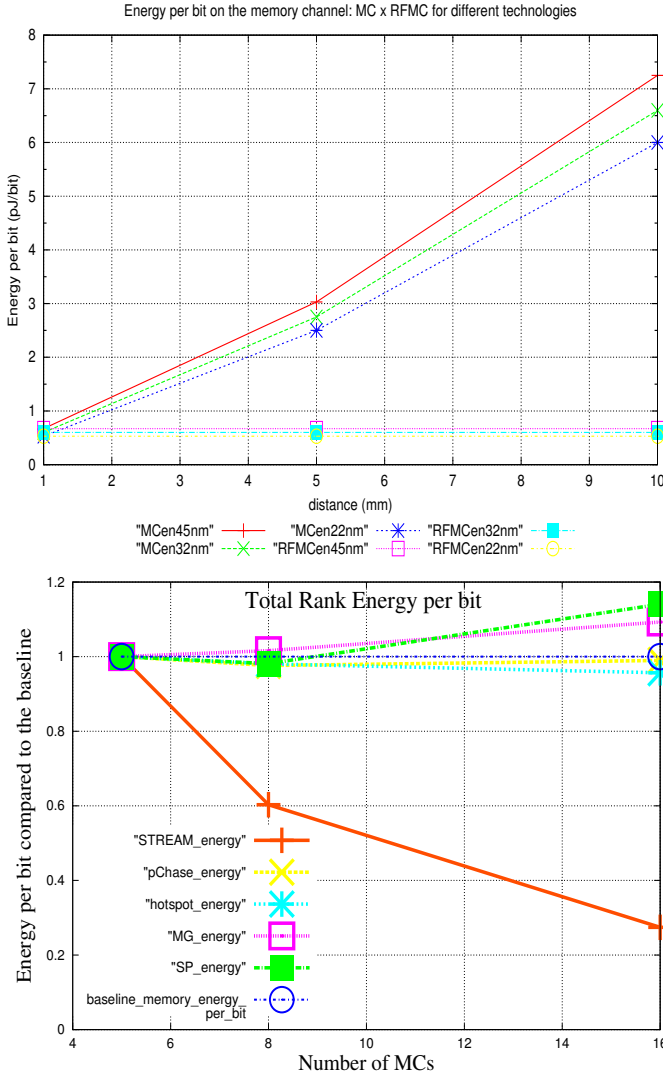

Fig. 9: top to bottom: (a) distance versus RFPad interconnection energy for different technologies; (b) rank energy per bit: STREAM_energy indicates a harmonic average of the four STREAM benchmarks (Table IIIb).

When having large bandwidth demand, the rank energy-per-bit level either decreases or keeps constant as RFMCs are scaled; for example, as RFMCs are scaled, in STREAM energy decreases up to 50% and in Hotspot up to 5% (compared to the baseline with 5 MCs, as explained in section IV-F), which demonstrates that in these benchmarks RFMC scaling significantly benefits not only performance but also power. For pChase (set with random behaviour) performance can be improved whilst the energy-per-bit level remains approximately constant for lower small counts. Instead, for SP and MG (which demand smaller bandwidths), energy levels increase up to 14% as the number of RFMCs is increased; if performance benefits are considered as a priority, this increase in energy levels is likely to be tolerated. By employing Micron power sheet [2], the typical rank energy-per-bit usage is estimated (STREAM benchmarks average, Table IIIb) at around 87 pJ/bit.

V. RELATED WORK

3Dstacking technique eliminates I/O pins and off-chip latencies, and allows smaller communication delays between ranks and MCs whilst MC scalability is thermally limited when stacking ranks [9]. Compared to 3Dstacking, *RFiop* rank layout distribution allows a 10.5% temperature reduction, whilst vertical RF-interconnections manufacturing are still an open research aspect, which does not allow a fair comparison.

10 TB/s-bandwidth Corona [10] optical memory system (160 GB/s/MC) has only 2 optical I/O pins and 2 optical I/O pads per optical memory. *RFiop* (CMOS) employs larger pad-count magnitudes, i.e., 8 RFPads, assuming 1:1 pin:pad ratio.

DIMM Tree [26] (i) reduces latencies by trading off bandwidth of RF-links to connect MC to ranks in a single-drop way. While RF/RFMCs are shared in both, *RFiop* employs around 4 RFPins versus 39 pins in DIMM Tree.

Liu [15] proposed QP lines as on-package inter-die CPW to communicate processor and memory, whilst operating at regular/RF frequency ranges. In *RFiop*, QP lines [15] are used as RFPads to connect RFMCs and on-package ranks, whilst QP parameters are used to demonstrate pad-reduction.

Muralidhara *et al.*[32] propose to map the data of applications to different channels and combine channel partitioning to scheduling to avoid applications interference. In this work, memory scheduling is not approached, therefore Muralidhara's technique is orthogonal and can be applied to *RFiop*.

In [33], Xie *et al.* propose that memory banks be dynamically partitioned according to thread utilization profiling. Janz *et al.* [34] propose a software scheduling framework in which an application interacts with the OS to determine its dynamic memory footprint utilization. In this report, memory thread scheduling is not approached, therefore Xie's and Janz' techniques can be orthogonally applied to *RFiop*.

Whilst Ausavarungrun *et al.*[35] employ a MC management technique that groups memory requests according to row-buffer locality first, then inter-application and FIFO scheduling, Kayiran *et al.*[36] manage to alleviate graphics processing units (GPU) contention for shared resources. These techniques could be orthogonally applied to *RFiop* RFMC row-buffers.

HMC[7] commercial solution employs sets of banks of memory dies, and processor/memory communication is done via serial/deserial, with 10-Gbit/s-I/O-links. Instead, *RFiop* employs typical DDR ranks and protocol, RF modulation and demodulation, over a scalable RFPads/RFMC. As a result, *RFiop* has about 48 Gbits/s data rate per I/O-channel, thus larger than HMC. To finalize, in the utilized settings, *RFiop* presents maximum aggregate bandwidth smaller than HMC, however it presents a significantly lower number of pads.

RFiop[16] lays out ranks on the on-package area and connects them to MCs via RF modulation (forming RFMCs) of data/address using QP (RFPads). As a follow-up, Marino[21] approached the I/O pin problem by defining scalable RFPins (microstrip interface) and adopting RFMCs connected to ranks - extension of LaMeres[22] RF-designed elements. In this study *RFiop* benefits are extended for more cores and different

memories. In addition, RF behavioural modeling of the RFpads is introduced, whilst energy and RFpads scaling behaviour are evaluated.

VI. CONCLUSIONS AND FUTURE WORKS

To address the I/O pad/pin problem, *RFiop* replaces the regular memory path with an RF path, formed by RF elements such as RFMCs and QP lines - defined as RFpads to replace I/O pads. Compared to the previous *RFiop* report [16], this investigation advances *RFiop* architecture via contributing to a (i) scaled bandwidth/performance; (ii) die area reduction; (iii) MC power and energy reduction, all compared to a baseline version with traditional I/O pads. The performance RFMC/RFpad scalability analysis previously evaluated for 16 cores is extended to 32 cores, including energy aspects. Furthermore, to the best of our knowledge, for the first time a modeling for RFpad that includes return loss, insertion loss and crosstalk noise as a function of RF bandwidth was developed from a real prototyped circuit aiming to assist the designer with important RF features.

We have demonstrated that *RFiop* techniques are also valid for other DDR family members: different data rates and widths. As a result, a significant improvement has been noticed when having twice the number of cores, which triggers a further investigation for the next generations.

As future endeavours, a future *RFiop* version with low power DDR (LPDDR) memories and more efficient RF-interconnections (e.g. carbon nanotubes) are considered. Rather than the utilization of the reported transmission line model[12], developing one for *RFiop* is also planned. Moreover, a power-saving strategy is also considered by including either memory system and last level cache system for any type of applications. Finally, an investigation of the scalability of optical pads due to the significant advance of optical interposers [11] is planned.

REFERENCES

- [1] Loh, G.H., "3D-Stacked Memory Architectures for Multi-core Processors," in *ISCA*, (DC, USA), pp. 453–464, IEEE, 2008.
- [2] "Micron manufactures DRAM components and modules and NAND Flash." Accessed date: 03/01/2017 ; <http://www.micron.com/>.
- [3] "ITRS HOME." Accessed date: 03/17/2017 ; <http://www.itrs.net/>.
- [4] "AMD Reveals Details About Bulldozer Microprocessors," 2011. accessed date: 01/05/2017 - http://www.xbitlabs.com/news/cpu/display/20100824154814_AMD_Unveils_Details_About_Bulldozer_Microprocessors.html.
- [5] Shane Bell et al., "TILE64TM Processor: A 64-Core SoC with Mesh Interconnect," in *ISSCC*, pp. 88–90, IEEE, 2008.
- [6] "Intel Fully Buffered DIMM." Accessed date: 01/13/2017 - http://www.intel.com/.../FBDIMM/.../Intel_FBD_Spec_Addendum_rev_p9.pdf.
- [7] "Hybrid Memory Cube Specification 1.0." Accessed date: 02/10/2017 ; <http://www.hybridmemorycube.org/>.
- [8] "Rambus." Accessed date: 02/26/2017 ; <http://www.rambus.com/>.
- [9] Healy, M et al., "A Study of Stacking Limit and Scaling in 3D ICs: An Interconnect Perspective," in *Electronic Components and Technology Conference*, (Washington, DC, USA), pp. 1213–1220, IEEE, 2009.
- [10] D. Vantrease et al., "Corona: System Implications of Emerging Nanophotonic Technology," in *ISCA*, (DC, USA), pp. 153–164, IEEE, 2008.
- [11] N. Hatori et al., "A Hybrid Integrated Light Source on a Silicon Platform Using a Trident Spot-Size Converter," *Journal of Lightwave Technology*, vol. 32, pp. 1329–1336, April 2014.
- [12] M. Frank Chang et al., "CMP Network-on-Chip Overlaid With Multi-Band RF-interconnect," in *HPCA*, pp. 191–202, 2008.
- [13] "Moore's Law, 40 years and Counting." Accessed date: 02/11/2017; <http://download.intel.com/technology/silicon/Interpack>.
- [14] Sai-Wang Tam et al., "RF-Interconnect for Future Network-on-Chip," *Low Power Network-on-Chip*, pp. 255–280, 2011.
- [15] Q. Liu, *Quilt Packaging: A Novel High Speed Chip-to-Chip Communication Parading for System-in-Package*. PhD thesis, Un. of Notre Dame, December 2007. .
- [16] Marino, M. D., "RFiop: RF-Memory Path To Address On-package I/O Pad And Memory Controller Scalability," in *ICCD, 2012, Montreal, Quebec, Canada*, pp. 183–188, IEEE, 2012.
- [17] David Wang et al., "DRAMsim: a memory system simulator," *SIGARCH Comput. Archit. News*, vol. 33, no. 4, pp. 100–107, 2005.
- [18] Nathan L. Binkert et al., "The M5 Simulator: Modeling Networked Systems," *IEEE Micro*, vol. 26, no. 4, pp. 52–60, 2006.
- [19] J.D. McCalpin, "Memory Bandwidth and Machine Balance in Current High Performance Computers," *IEEE TCCA Newsletter*, pp. 19–25, dec 1995.
- [20] "Ansoft High-Frequency Structure Simulator (HFSS), Ansoft Inc., Pittsburgh, PA." Accessed date: 09/20/2017 ; <http://www.ansys.com/en-gb/products/electronics/ansys-hfss>.
- [21] Marino, M. D., "RFiof: An RF approach to the I/O-pin and Memory Controller Scalability for Off-chip Memories," in *CF, May 14-16, Ischia, Italy*, pp. 100–110, ACM, 2013.
- [22] LaMeres B.J., et al., "Off-Chip Coaxial to Microstrip Transition Using MEMs Trench," *3D/SiP Adv. Packaging Symposium*, vol. 33, no. 1, 2008.
- [23] "CACTI 5.1." Accessed Date: 02/20/2017; <http://www.hpl.hp.com/techreports/2008/HPL200820.html>.
- [24] Sheng Li et al., "McPAT: an integrated power, area, and timing modeling framework for multicore and manycore architectures," in *MICRO'09*, (New York, USA), pp. 469–480, ACM, 2009.
- [25] W. Huang et al., "Hotspot: Acompact Thermal Modeling Methodology for Early-stage VLSI Design," *TVLSI*, vol. 14, no. 5, pp. 501–513, 2006.
- [26] K. Therdsteerasukdi et al., "The dimm tree architecture: A high bandwidth and scalable memory system," in *ICCD*, pp. 388–395, IEEE, 2011.
- [27] J. Tuck et al., "Scalable Cache Miss Handling for High Memory-Level Parallelism," in *MICRO*, (DC, USA), pp. 409–422, IEEE, 2006.
- [28] "The pChase Memory Benchmark Page." Accessed date: 02/06/2017 ; <http://pchase.org/>.
- [29] Shuai Che et al., "Rodinia: A benchmark suite for heterogeneous computing.," in *IISWC*, pp. 44–54, IEEE, 2009.
- [30] "NAS Parallel Benchmarks." Accessed date: 03/20/2017; <http://www.nas.nasa.gov/Resources/Software/npb.html/>.
- [31] G. Byun et al., "An 8.4Gb/s 2.5pJ/b Mobile Memory I/O Interface Using Bi-directional and Simultaneous Dual (Base+RF)-Band Signaling," in *ISSCC*, pp. 488,490, IEEE, 2011.
- [32] Muralidhara, S.P. et al., "Reducing memory interference in multicore systems via application-aware memory channel partitioning," in *MICRO*, (New York-NY), pp. 374–385, ACM, 2011.
- [33] Xie, M. et al., "Improving system throughput and fairness simultaneously in shared memory CMP systems via Dynamic Bank Partitioning," in *HPCA*, pp. 344–355, IEEE, 2014.
- [34] Jantz, M. R. et al., "A framework for application guidance in virtual memory systems," in *VEE*, pp. 344–355, ACM, 2013.
- [35] Ausavarungnirun, R. et al., "Staged Memory Scheduling: Achieving High Performance and Scalability in Heterogeneous Systems," in *ISCA*, (Washington-DC, USA), pp. 416–427, IEEE, 2012.
- [36] Kayiran, O. et al., "Managing gpu concurrency in heterogeneous architectures," in *MICRO-47*, (USA), pp. 114–126, IEEE, 2014.

VII. AUTHOR BIOGRAPHY

Mario Donato Marino is currently a Senior Lecturer in Leeds Beckett University. His PhD/MSc were obtained at the University of Sao Paulo. Mario has worked in several institutions such as University of Sao Paulo and Texas at Austin and co-authored papers in computer architecture and high-performance computing. He is an AE in Inderscience IJES and has been serving in international journal/conferences PCs. Mario is a member of IEEE and ACM.

