



LEEDS
BECKETT
UNIVERSITY

Citation:

Dixon, S and Guest, E and Dixon, MB and Elliot, J and Mullier, D (2011) DScnt Final Report. Technical Report. Leeds Metropolitan University.

Link to Leeds Beckett Repository record:

<https://eprints.leedsbeckett.ac.uk/id/eprint/858/>

Document Version:

Monograph (Other)

The aim of the Leeds Beckett Repository is to provide open access to our research, as required by funder policies and permitted by publishers and copyright law.

The Leeds Beckett repository holds a wide range of publications, each of which has been checked for copyright and the relevant embargo period has been applied by the Research Services team.

We operate on a standard take-down policy. If you are the author or publisher of an output and you would like it removed from the repository, please [contact us](#) and we will investigate on a case-by-case basis.

Each thesis in the repository has been cleared where necessary by the author for third party copyright. If you would like a thesis to be removed from the repository or believe there is an issue with copyright, please contact us on openaccess@leedsbeckett.ac.uk and we will investigate on a case-by-case basis.



DScent Final Report

Leeds Metropolitan University

(Faculty of Arts, Environment & Technology)

Authors: S. Dixon, Dr M. Dixon, Dr J. Elliot, Dr E. Guest, Dr D. Mullier
Version: 2.0
Date: 31st January 2011
Status: Issue
Document
Reference: D:\DScentFinalReportv2_0.doc

1. Document Control

1.1 Quality Review

Name	Role	Signature	Date
John Elliott	AI Expert		
Elizabeth Guest	Dscent Principle Investigator		
Duncan Mullier	AI Expert		

1.2 Change History

Version	Date	Author	Change Description
0.1	07/09/2010	S. Dixon	Initial Draft
0.2	30/09/2010	S. Dixon D. Mullier	Amendments regarding the neural network
0.3	12/10/2010	S.Dixon D.Mullier J.Elliott	Amendments regarding the behavioural based AI
1.0	01/11/10	S.Dixon D.Mullier J.Elliott E.Guest	Amendments post walkthrough for Issue.
2.0	31/01/2011	S.Dixon M.Dixon E.Guest D.Mullier J.Elliott	Amendments post article submissions (no code in appendixes)

1.3 Distribution

Name	Title
Elizabeth Guest	Dscent Principle Investigator
Mark Dixon	Senior Lecturer
John Elliot	AI Expert
Duncan Mullier	AI Expert
Tom Ormerod	DScent Lead Partner
EPSRC	Final Report
Nicholas M	Stake Holder
Andrea Davis	Senior Officer (University Research Office)
Richard Lampard	Head of Networks Research
Nick Cope	Associate Dean and Head of School

2. Table of Contents

1. Document Control	2
1.1 Quality Review	2
1.2 Change History.....	2
1.3 Distribution	2
2. Table of Contents.....	3
3. Introduction	5
4. The Games	5
4.1 Cutting Corners Board Game	6
4.2 The Location Based Game.....	7
5. Phase One Development.....	10
5.1 Neural Networks.....	11
5.1.1 Different Types of Neural Network.....	11
5.2 Cutting Corners Board Game Data	12
5.3 Cutting Corners Board Game Results	13
5.3.1 The Mann Whitney U Test	13
5.3.2 Altering the Result Threshold.....	14
5.4 Summary of Results	15
5.5 Phase One Conclusion.....	16
6. Phase Two Development.....	17
6.1 DScentTrail System.....	17
6.1.1 User Interface Design	17
6.1.2 Technical System Design	21
6.1.2.1 DScent.Model Class Model	22
6.1.2.2 GUI Class Model	23
6.1.2.3 GUI DScentTrail Main Window (Object Model)	24
6.1.2.4 GUI Database Connection (Object Model)	25
6.1.2.5 GUI New Suspect (Object Model)	26
6.1.2.6 GUI Meetings Set Up (Object Model)	27
6.1.2.7 GUI Time Interval Set Up (Object Model).....	28
6.1.3 Screen Shots	29
6.1.3.1 New Database Connection.....	30
6.1.3.2 New Primary Suspect.....	31
6.1.3.3 Meetings Configuration	32
6.1.3.4 Time Interval Configuration	33
6.1.3.5 Primary Suspect Timeline Showing Non-deceptive Behaviour	34
6.1.3.6 Primary Suspect Timeline Showing Deceptive Behaviour.....	35
6.2 Artificial Intelligence (AI).....	36
6.2.1 Neural Network	36
6.2.1.1 Neural Network Input File.....	37
6.2.2 Behavioural Based Artificial Intelligence	40
6.2.2.1 Theme 5.0	40
6.2.2.1.1 Temporal Analysis of Results	41
6.2.2.1.2 Event Based Analysis of Results	43
6.2.2.2 Behavioural Based AI Conclusions	45
7. Conclusions	45

Appendix A - DScent Data Dictionary	47
Appendix B - Data File	60
Appendix C - Results Cross Reference	62
Appendix D - Test Results	65
Appendix E - The Root Mean Square Error (RMSE) During Training	68
Appendix F - Calculation of U Value for Mann Whitney U Test.....	74
Appendix G - Altered Results Threshold.....	75
Appendix H – Theme Category Table.....	76
Appendix I – Theme Data File	78
8. References.....	86

3. Introduction

DScent was a joint project between five UK universities combining research theories in the disciplines of computational inference, forensic psychology and expert decision-making in the area of counter-terrorism. This document discusses the work carried out by Leeds Metropolitan University which covers the research, design and development work of an investigator support system in the area of deception using artificial intelligence. For the purposes of data generation along with system and hypothesis testing the project team devised two closed world games, the Cutting Corners Board Game and the Location Based Game.

DScentTrail presents the investigator with a 'scent trail' of a suspect's behaviour over time, allowing the investigator to present multiple challenges to a suspect from which they may prove the suspect guilty outright or receive cognitive or emotional clues of deception (Ekman 2002; Ekman & Frank 1993; Ekman & Yuille 1989; Hocking & Leathers 1980; Knapp & Comadena 1979). A scent trail is a collection of ordered, relevant behavioural information over time for a suspect. There are links into a neural network, which attempts to identify deceptive behavioural patterns of individuals.

Preliminary work was carried out on a behavioural based AI module which would work separately alongside the neural network, with both identifying deception before integrating their results to update DScentTrail. Unfortunately the data that was necessary to design such a system was not provided and therefore, this section of research only reached its preliminary stages.

To date research has shown that there are no specific patterns of deceptive behaviour that are consistent in all people, across all situations (Zuckerman 1981). DScentTrail is a decision support system, incorporating artificial intelligence (AI), which is intended to be used by investigators and attempts to find ways around the problem stated by Zuckerman above.

4. The Games

For data protection, security and ethical reasons real life data could not be used and therefore, for the purpose of data generation and testing of hypothesis, the project team devised two closed world games.

During phase one, data was generated by means of a board game (Cutting Corners Board Game). Players rolled a dice and travelled around a board buying items and completing tasks. During phase two, a location based game was designed, this was similar to the board game, with the main difference being that the game participants traversed certain locations within Nottingham University Campus using GPS enabled devices to communicate, navigate and purchase items, the concept of teams was introduced within phase two.

4.1 Cutting Corners Board Game

Game participants either acted as *potentially dishonest* builders constructing part of an Olympic stadium, or terrorists masquerading as builders with the aim of planting explosives. The game was divided into rounds with a certain number of dice throws per player and the winner was the first to accomplish their aim.

Each game consisted of four players, White (W), Yellow (Y), Blue (B) and Green (G). Between one and three players acted as terrorists (t). During the game the players could visit three different types of virtual location; the Builders Yard (BY) selling virtual construction blocks, soil and fertiliser, the Electronics Store (ES) selling virtual wiring and dynamite and the Olympic Site/Goal (Go) where virtual items could be unloaded. An initial amount of virtual cash was given to each player to purchase items and a virtual van. During the game van searches and van weight checks were carried out where players displayed two items in their van and were weighed respectively. If the van exceeded the maximum weight allowance of 100kg the player did not receive a cash reward. For each van weigh check all players would receive the cash payment regardless of whether they were weighed, provided they were not found overweight. On completion of each round the sum of the items sold from each shop was calculated. Figure 4.1 shows an example of information that may have been known at the end of a game.

Game	Round	Player	Location1	Location2	Location3	Wire	Dynamite	ConBlock	Soil	Fertiliser	Van Weight	Wire Sold	Dyn Sold	Con Sold	Soil Sold	Fert Sold
13	5	W	ES	Go								6	2	3	1	0
		Y	BY	Go												
		B	ES	Go												
		G(t)	BY	Go												
8		W	BY									10	3	2	1	1
		Y	ES			1	1				60					
		B	BY													
		Gt	ES				2				70					
11		W	Go	BY					2		100	0	1	0	2	0
		Y	ES			1	1				70					
		B	Go													
		G(t)	Go													
14		W										1	0	5	3	1
		Y	BY						1	1						
		B	BY								200					
		G(t)	ES	BY		1		1			60					
17		W	Go									0	0	0	1	0
		Y	Go	BY					1		50					
		B	Go													
		G(t)	Go													
20		W	ES									4	2	2	1	0
		Y	BY	Go												
		B	ES													
		G(t)	BY													

Figure 4.1 Board game example data

4.2 The Location Based Game

The Location Based Game was similar to the board game where participants were either acting as *potentially dishonest* builders constructing part of an Olympic stadium, or terrorists masquerading as builders with the aim of planting explosives. Participants from a variety of different backgrounds were recruited to partake in the game trials over a number of months. These participants traversed set locations (see figure 4.2) using GPS enabled devices to communicate, navigate and purchase items. For reasons discussed in the conclusions, only 2 games worth of data was available for testing purposes.

Each game comprised of four teams, and each team comprised of three players, a foreman, and two of the following tradesmen: an electrician; an explosives expert; or a builder. The games were divided into four building tasks and the winning team was the first to complete all four of these tasks. Virtual cash rewards were given to teams upon completion of tasks. Each task involved specific team members being in certain locations at certain times. They involved participants purchasing specific items and unloading these at their site. One team member was given the role of van driver and therefore could purchase items. Vans were virtual and could be transferred between team members via the mobile device.

The GPS locations consisted of four shops; four sections of the Olympic site, one per team; and three fixed checkpoints where players would be checked by investigators and either given a cash reward or penalty. Police investigators performed random checks on players who they suspected to be behaving suspiciously, the same rules applied as with the fixed checkpoints. The four shops consisted of a local electrical store selling dynamite sticks and wiring looms, but only ever one item type at any point in time; a national electrical store this was fully stocked at all times; a local and a national builder's yard selling construction blocks, soil and fertiliser. Again the local store only stocked one item type at any point in time and the national store carried full stock of all three item types. To complete the game all three types of tradesmen were required, therefore, the foremen were required to sub-contract players between teams to perform specific tasks. The GPS enabled devices recorded all player movements within the game area. The same devices were used to store and transfer money, transfer vans between team members and to purchase, reveal and drop off virtual items at the sites. On completion of a game all team members were interviewed separately by police investigators, this encouraged the participants to devise specific, possibly deceptive strategies in line with their role.

All data captured from the games was stored in the DScent database which can be seen in figure 4.3 below. For a description of the entities and attributes please refer to Appendix A.



©2011 Google, Map Data ©2011 Tele Atlas

Figure 4.2 – Map of Location Based Game Playing Area

Scale: 45m (Approx)

Dscent

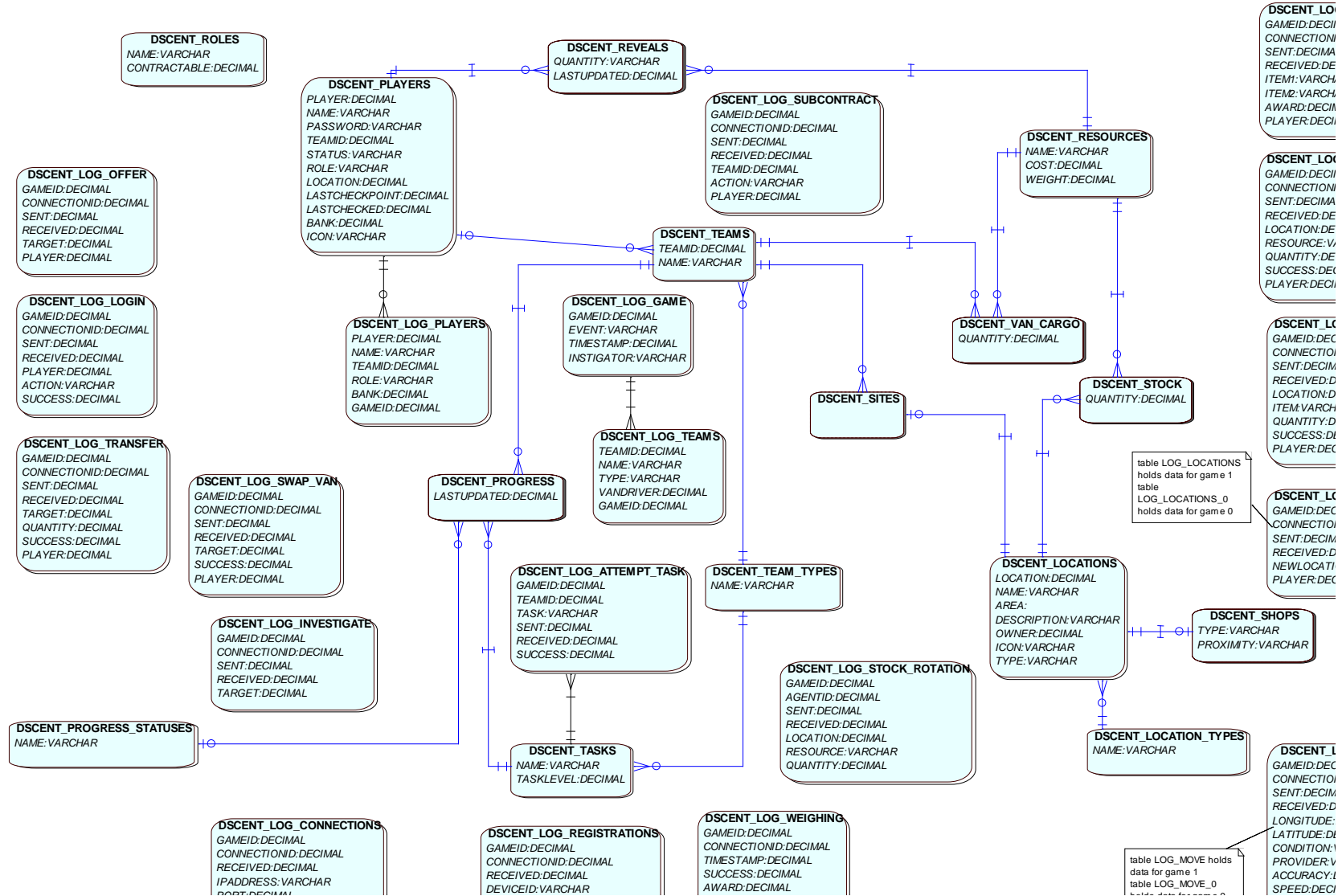

Figure 4.3 – Dscent Data Model

5. Phase One Development

The Cutting Corners board game data was used for phase one development which consisted of various types of neural networks.

The use of various AI techniques, such as data mining, artificial neural networks, symbolic AI and Case Based Reasoning, for counter-terrorism has been advocated by Markman et al (2003) and Marappan et al (2008). Projects which consider such techniques are discussed below.

Scianta Intelligence (2001) provides a precise definition of data mining:

“Data Mining, also called Knowledge Discovery, is a general term for a variety of interlocking technologies that, used together, find, isolate, and quantify patterns hidden in large and often disparate collections of data. As a general knowledge extraction process, its primary goal is the discovery of nontrivial and potentially valuable hidden in local files, databases, and in repositories scattered across distributed networks.”

Schneier (2006) in his article on *Why Data Mining Won't Stop Terror*, writes that data mining works best when you're searching for a well-defined profile, a reasonable number of attacks per year and a low cost of false alarms. Rudmin (2006), Professor of Psychology at the University of Tromso, Norway, is also sceptical regarding data mining techniques used for counter-terrorism and disregards them completely as in order to make a Bayesian computation, he estimates that at best in the USA there would be a base-rate of 1 terrorist per 300,000 people and that if a surveillance monitoring system had an accuracy rate of 40% positive identification of real terrorists then according to Bayes' Theorem (Joyce 2008) the misidentification rate would be .01%, or 30,000 innocent people. Rudmin stresses that these numbers are simply examples based on one particular technology.

Data mining was not used on DScent since it is generally used for extracting information from large quantities of data that is collected for reasons other than for the purpose of mining itself. The DScent data was explicitly designed and collected for identifying suspicious behaviour. DScent would not encounter the problems outlined by Professor Rudmin of having to potentially question 30,000 innocent people as the set did not contain the entire population, it is merely a well established sub-set. Ware (2002) in his paper on antiterrorism states that neural networks do not lend themselves easily to real-time updated information and has concerns regarding the limited historical data on terrorist attacks, he further comments on how terrorist tactics are not static and change over time. These issues have been carefully considered during the project and are discussed further below.

The reason for choosing a neural network as an AI application, was that a neural network is the most likely type of computer system that will work with a non-polynomial problem such as behavioural patterns of humans. Although Ware's (2002) observations may be valid, by identifying the key input factors

to the neural network and keeping these to an absolute minimum, the amount of historical data required for training will be far less. Furthermore, if the neural network can identify deception amongst humans from a small amount of inputs then we are getting closer to that “well-defined profile” of which Schneier speaks.

5.1 Neural Networks

The neural networks were developed within the JOONE (Java Object Oriented Neural Engine) GUI editor. JOONE is an open source, object based neural network framework written in Java (Marrone 2010) with a graphical front end. EasyNN-plus (Neural Planner Software 2010) was used to validate the output from Joone. The tool is limited, though adequate to quickly validate the results.

Figure 5.1 shows one of the experimental configurations of feed-forward back-propagation neural network used for the DScent project. This configuration shows the input data from an Excel spreadsheet entering the input layer containing 122 neurons, progressing to a hidden layer containing 10 neurons, before finally reaching the output layer containing a single neuron. The output value is in the range zero to one and is passed into an Excel spreadsheet, all three layers utilise the sigmoid activation function (Mitchell 1997). The Teacher layer trains the network by presenting it with complete examples, including whether the example is a terrorist or not (this is known as supervised learning). The training is then presented graphically via a Root Mean Square Error chart (RMSE) see section 5.3 Cutting Corners Board Game Results for more details.

5.1.1 Different Types of Neural Network

There are two main types of neural network and these are classified by the method in which they train, supervised and unsupervised.

Figure 5.1 below, is an example of one of the neural network architecture which was chosen within phase one. This is a feed forward back propagation network which is a type of supervised neural network.

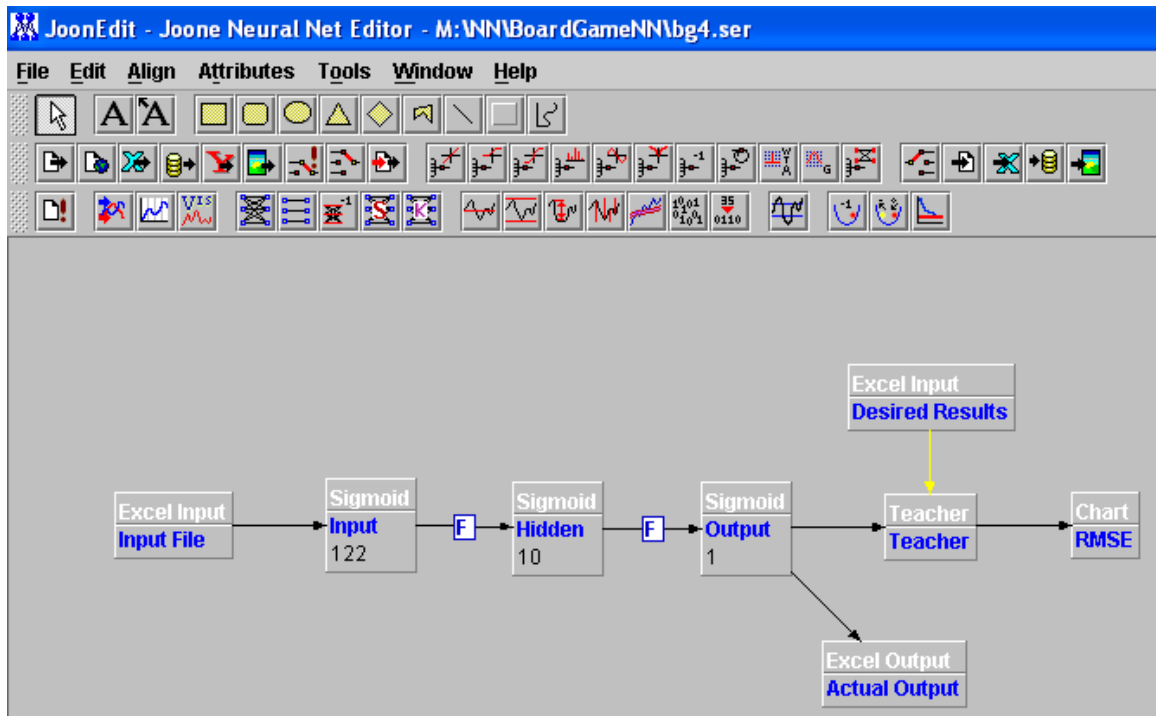

Figure 5.1 An example of a neural network architecture created within the Joone Neural Network Editor

5.2 Cutting Corners Board Game Data

The data from the Cutting Corners board game was collated into an excel spread sheet. (See Appendix B) The spread sheet contained 144 rows of game data which resulted from playing 36 games. This game data was divided into separate training and test files with a ratio of 4:1 respectively. Three types of training and three types of test files, each containing varying numbers of terrorists were created for each variation on the input file as can be seen in table 5.1 below. Note that the training and corresponding test files have been colour coded for ease of recognition in the results tables shown within the appendices.

File	Record Range	File Partition	Number of Terrorists
Training File 1	29-144	Train with last 116	48
Training File 2	1-116	Train with first 116	40
Training File 3	1-88, 97-100, 105-108, 113-116, 121-124, 129-132, 137-144	Train with least number of terrorists	35
Test File 1	1-28	Test with first 28	7
Test File 2	117-144	Test with last 28	15
Test File 3	89-96, 101-104, 109-112, 117-120, 125-128, 133-136	Test with highest number of terrorists	20

Table 5.1 Standard training and test files

The effectiveness of a neural network is greatly reduced when the number of variables (horizontal), do not have adequate training pattern examples (vertical), as the network does not have the opportunity to explore a large proportion of the possibilities. It is therefore necessary to prune the input file of unnecessary variables prior to training. It is apparent that by knowing which variables are contributing to the neural network (Sexton & Sikander 2002) the developer has not only improved the effectiveness of the networks ability to generalise but also, and maybe more importantly, they have gained a better understanding of the problem. Multiple experiments were performed excluding different variables within the import file to enable the ultimate level of accuracy given the number of training patterns available.

The Results Cross Reference table in Appendix C shows which variables were either included or excluded from each experiment.

5.3 Cutting Corners Board Game Results

Due to the severe lack of training data the results were predictably inaccurate, though much better than anticipated. This did not however present a problem, as the purpose of phase one was to experiment with different tools; architectures; input variables; the ratio of positive and negative patterns presented within the training and test files and to identify the optimal classification threshold within the output. 55 neural network experiments were performed within phase one, the summation of these results can be seen in Appendix D. A threshold of 0.5 was used as the cut-off point, where 0 indicated 'builder' and 1 indicated 'terrorist', therefore any result greater than or equal to 0.5 was deemed to be a terrorist and any result less than 0.5 was deemed to be a builder. The Root Mean Square Error (RMSE) (Levinson 1946) was plotted for each experiment during training, see Appendix E, to establish the optimum number of times the neural network was presented with the entire training set, known as an epoch. The X axis of the RMSE graphs represents the number of epochs and the Y axis represents the error. It is crucial not to over train the network as it has the potential to memorise the training data and loses the ability to generalise with different data.

5.3.1 The Mann Whitney U Test

The Mann Whitney U test (Mann & Whitney 1947) looks at the differences between two sets of result data to ascertain whether the variance between is large enough that it could not have occurred by chance alone. Firstly, the least successful set of neural network results (experiment J) were compared against the most successful (experiment I). Secondly, the most successful set (experiment I) were compared against a random set of 28 zeros and ones, these data sets can be seen in Appendix F. An online automated calculation tool (Avery 2007) was used to perform the final part of the tests, as significance lookup tables do not have U values beyond 30, the results for the first test are shown in Figure 5.2.

n1	n2	U	P (two-tailed)	P (one-tailed)
28	28	336	0.365644*	0.182822*
normal approx			0.358796*	0.179398*
z = -0.917663				

*These values are approximate.

The two samples are not significantly different ($P \geq 0.05$, two-tailed test).

Figure 5.2 - Results from automated calculator for comparison of worst against best neural network

The test showed that there was not a significant difference between the results of the best and the worst neural networks. Though, when the best neural network (experiment I) results were compared against a random set, the significance was rated as 'highly significant', proving the value of the neural network even with such small amounts of training data, see results below in Figure 5.3 below.

n1	n2	U	P (two-tailed)	P (one-tailed)
28	28	143	2.8e-05*	1.4e-05*
normal approx			4.49732e-05*	2.24866e-05*
z = -4.08032				

*These values are approximate.

The difference between the two samples is highly significant ($P < 0.001$, two-tailed test).

Figure 5.3 - Results from automated calculator for comparison of best neural network results against a random set

5.3.2 Altering the Result Threshold

By altering the threshold to determine whether an output was positive or negative had a direct effect on the successfulness of the network. For the purpose of this experiment three of the neural network tests were chosen along with their associated three input files, resulting in nine test cases, see Appendix G. Note the 'Event' column represents a comparison between the desired output and the initial actual output when the threshold value was 0.5. 'A' represents 'Added', this is where a positive result was generated where it originally would have been negative and 'M' represents 'Missed', which is where a negative result was generated where it originally would have been

positive. Initially, the result was classified as being positive if the resulting number fell between 0.5 and 1.0, else it was negative. If this arbitrary result threshold value of 0.5 was shifted, so as anything greater than or equal to 0.13 became a positive result and anything less than 0.13 became a negative result, then the number of true positives was increased from 53% to 60%. This did however, have a slightly negative effect on the total number of correct classifications within the test files, taking the percentage down from 64% to 60%. This percentage loss was deemed acceptable, as it was not identifying terrorists but merely flagging those who merited further investigation, resulting in a slightly larger subset.

The stakeholders were consulted about what they wanted from the project, in particular whether they wanted to know who the terrorists were from a small previously identified population or whether they wanted the system to identify a subset that merited further investigation, they chose the latter. By moving the threshold to reduce false positives, the project met this objective. Jonas and Harper in their book on Effective Counterterrorism and the Limited Role of Predictive Data Mining discuss this point further (Jonas & Harper 2006). They state that it is a waste of the tax payers' money developing data mining techniques to solve terrorism. This may be true, though to develop a decision support system which will provide a subset of potential terrorists for further investigation is quite different.

5.4 Summary of Results

This initial set of neural network experiments showed on average a 60% success rate and at best, a 68% success rate for correctly identifying terrorist behaviour (with a threshold of 0.13). The winning architecture consisted of all three layers; input, hidden and output using the sigmoid activation function. The hidden layer contained 10 neurons which resulted in 11% of the number of variables contained within the input file. The information variables which proved to be of importance were 'locations', 'Stock Items' and 'Stock Take'. The variables which were excluded were 'Game Number', 'Colour' and 'Van Weight'. The patterns within the training file were presented to the neural network randomly rather than in sequence and over 1500 epochs. Finally, the result threshold was set to 0.13.

There were certain rows within the input file that the neural network consistently classified either correctly or incorrectly, obtaining either a minimum of a 90 percent success rate throughout all 50 neural network experiments, else a maximum of 10 percent success rate throughout. The proportion of these successful and unsuccessful rows that were terrorist patterns of behaviour was 14% and 71% respectively. After analysing these successful and unsuccessful rows it was apparent that the neural network had generalised much better for the builders, this was however expected as there were more building examples in the training files. From the correctly identified terrorist rows, the neural network performed far better for those who used dynamite to carry out the tasks rather than those using fertiliser, this is again thought to be because less terrorists were using fertiliser, too few to

generalise on. Not all games were played in full; they ended when one player won, which is another reason for the neural network incorrectly classifying records. This of course would also be the case in reality, you would not want to wait until the terrorist event had occurred before an arrest was made. The next stage of development would have been to introduce the concept of pattern completeness, this would be to train and refine the neural network on patterns with varying degrees of completeness and identifying chunks of behaviour which were deceptive in isolation. This type of discrete deception identification would be far more valuable in reality.

Problem domains such as counter-terrorism intrinsically contain many information variables. Each time a variable is added, the number of possible pattern combinations increases exponentially. Therefore, with 100 variables within the input file, a vast number of rows would be required to cover just a small number of possible combinations of data. Take for example, the winning neural network where only location information, stock items and stock take information was used (92 variables), each variable had an average of 4 possible values, i.e. 4^{92} , resulting in 2.45×10^{55} rows of training data required to cover every possible combination. This poses a problem, as large numbers of historical patterns of terrorist behaviour are not available.

5.5 Phase One Conclusion

The neural network showed extremely promising results, on average a 60% success rate and at best a 68% success rate for correctly identifying deceptive behaviour, taking into account the sparse amount of training data. Future work is underway to develop a method for generating behavioural data, building on the rules of the board game. This can be done by combining intelligent agents (Evertsz 2009) with gene expression programming (Ferreira 2006) and the use of an Emdros database (Petersen 2004).

A neural network has great potential as being a powerful tool in the quest to counter-terrorism, though certain pre-requisites must be met. These include providing it with an adequate set of training data to perform a satisfactory level of generalisation, performing some pre-processing to perform tasks which a neural network has difficulty in doing, for example cross referencing rows against column data and time must also be taken to arrive at an optimal results classification threshold.

6. Phase Two Development

The Location Based Game data was used to help design and test the DScentTrail System during Phase two of the project. Phase two was split between three areas, the DScentTrail System and two external AI modules which included the neural network and a symbolic AI module.

6.1 DScentTrail System

A graphically based software product was developed to help visualise game data. Extensive research was carried out to ensure that the interface was designed in such a way that it would benefit investigators in an interview situation and not only serve as a visualisation tool within the project. Various types of information were collated, processed and then presented by means of a 'scent trail'. DScentTrail has links into a neural network that attempts to identify deceptive behavioural patterns of individuals, giving further enrichment to the information available to the investigator, not only by supplying them with related information that may not have been possible to find manually but also reducing their cognitive overload, allowing them to concentrate on their interviewing techniques.

The DScentTrail System was designed and specified using various techniques from the Unified Modelling Language (Booch, Jacobson & Rumbaugh 2005) (UML), such as class and object modelling within the QSEE Superlite Development Environment (Dixon 2004). All user interface design was created using Microsoft Visio and was written in Java programming language (Flanagan 2002) within the Eclipse Integrated Development Environment (The Eclipse Foundation 2004) (IDE).

6.1.1 User Interface Design

Various screen designs were created, figure 6.1 shows the primary suspect screen with two secondary suspects selected. The primary suspect window is located to the left and stays constant throughout the investigation, whereas various secondary suspect windows may be activated as and when required.

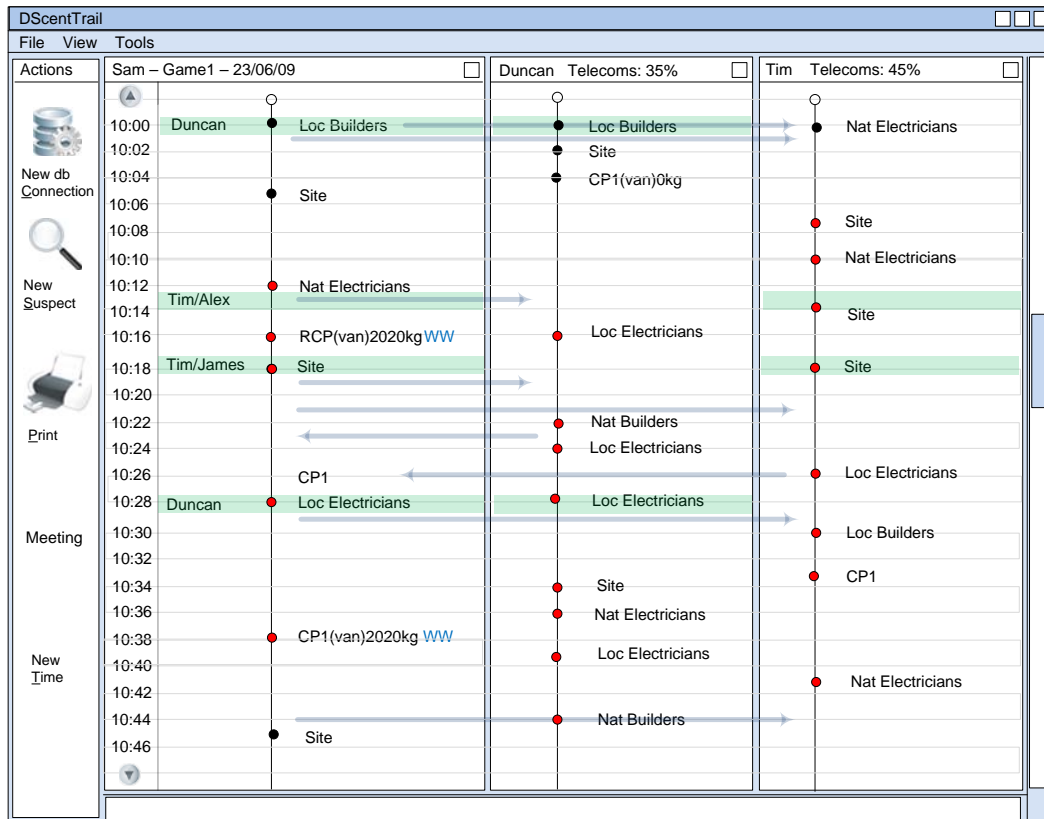

Figure 6.1 - DScentTrail screen design (Primary and secondary suspects)

For all windows within the DScentTrail system, time travels down the y axis and suspect information is displayed along the x axis, both of which are scrollable. All windows display a suspects time-line. A time-line represents the 'scent trail' and shows a series of events for a player within a game, the name of the suspect is displayed at the top of the window. A time ordered list of locations and police checks is shown down the right side of the time-line, these locations are listed in the 'The Location Based Game' section above. If a participant who is driving a van enters a fixed or has an investigator initiated checkpoint additional information is displayed, consisting of the weight of the van and up to two items which they must reveal. In figure 2 above, Sam at 10.16am had an investigator initiated (random) checkpoint, had a van weight of 2020kg and revealed two wiring looms. At 10.26am Sam enters checkpoint 1 but as she is not driving a van, no additional information is displayed. Table 1 shows the codes used for the various stock items when revealed.

Stock Item	Code
Dynamite	D
Wiring Loom	W
Construction Block	B
Fertiliser	F
Soil	S

Table 6.1 - Stock Item Code Cross Reference Table

The information down the left side of the primary suspect's time-line shows potential meetings. A meeting is defined by the investigator; it is where two players are within x meters for greater than y seconds. Certain locations may be excluded, for example shops, checkpoints and sites, as these are areas where participants may naturally gather. To display a secondary suspect's time-line the investigator would right click the mouse over a name down the left side of the primary suspect's time-line, alternatively they may select 'New Suspect' from either the top menu bar under 'File' or from the side menu bar. Multiple secondary suspect time-lines may be displayed at one time.

The blue horizontal arrows in figure 2 show telecommunication activity between primary and secondary suspects with the arrow head indicating the direction of the call. The green horizontal bars indicate potential meetings, again between the primary and secondary suspects. Hovering the mouse over either type of highlighter bar provides additional information, for example call or meeting duration and detailed meeting location information. Nodes on the time-line are either shown in black or red, with black indicating normal behaviour and red indicating potentially deceptive behaviour; the red nodes varying in hue depending on the combined certainty factor generated from the AI modules, drawing the investigators attention to a potential terrorist.

The investigator has the option to highlight alerts for all movements into locations which have taken greater than the calculated maximum travel time, figure 6.2 displays a detailed trajectory view. Here the dotted arrow shows the player leaving the local electrical store at 10.28am, stopping for two minutes, continuing, stopping for a further three minutes before arriving at checkpoint 1 at 10.38am. The investigator may choose to hover their pointer over the rest events to view all other participants within a close proximity from the primary suspect during that rest period, which may indicate a reason for the rest period.

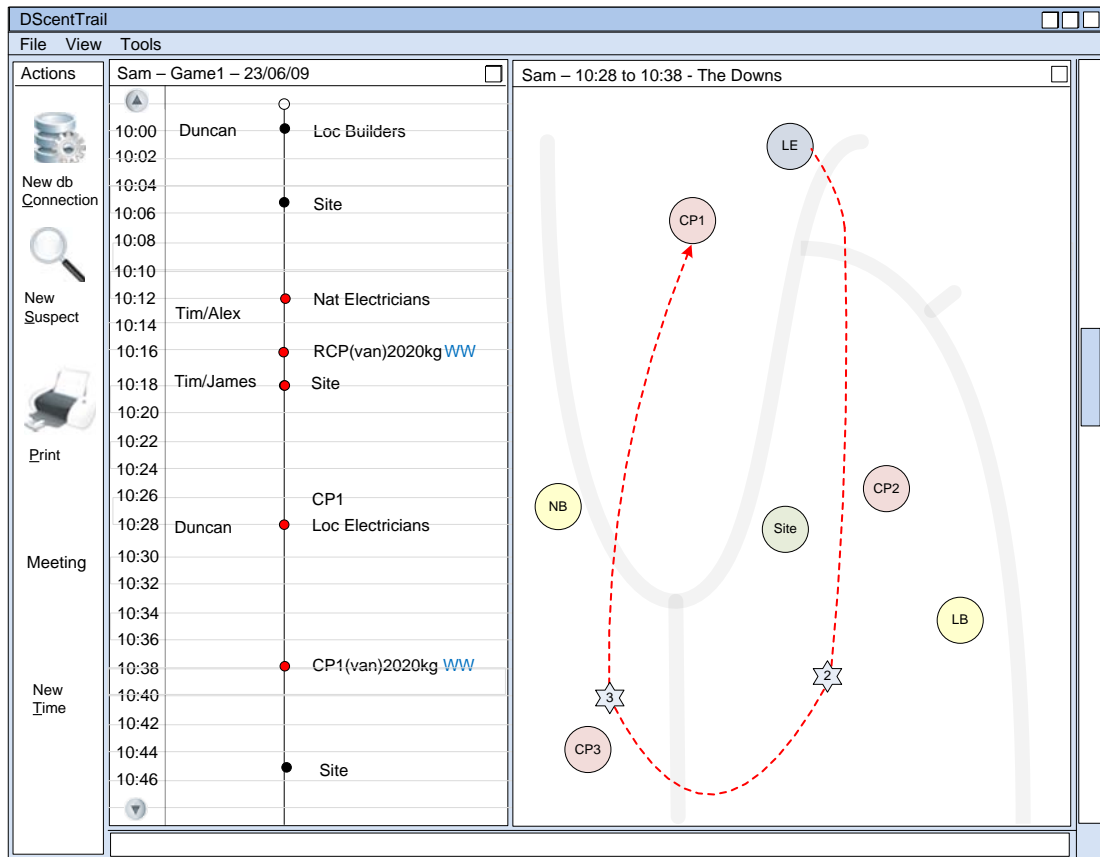

Figure 6.2 - DScentTrail screen design (Trajectory of route)

Various reporting screens are available to the investigator. Figure 6.3 shows a telecommunications bar chart for a primary suspect within a game. Other participants who have either made or received calls from the primary suspect during a game are represented along the x axis and the number of calls is displayed along the y axis. A similar chart is available for meetings behaviour during a game. These reporting summary screens may be accessed via the View menu. In addition, the telecommunications chart may be accessed by right clicking the mouse on any of the handset icons down the primary suspect's time-line then selecting 'view summary report'. The meetings chart may be selected by right clicking the mouse on any of the names down the left side of the primary suspect's time-line and selecting 'view summary report'.

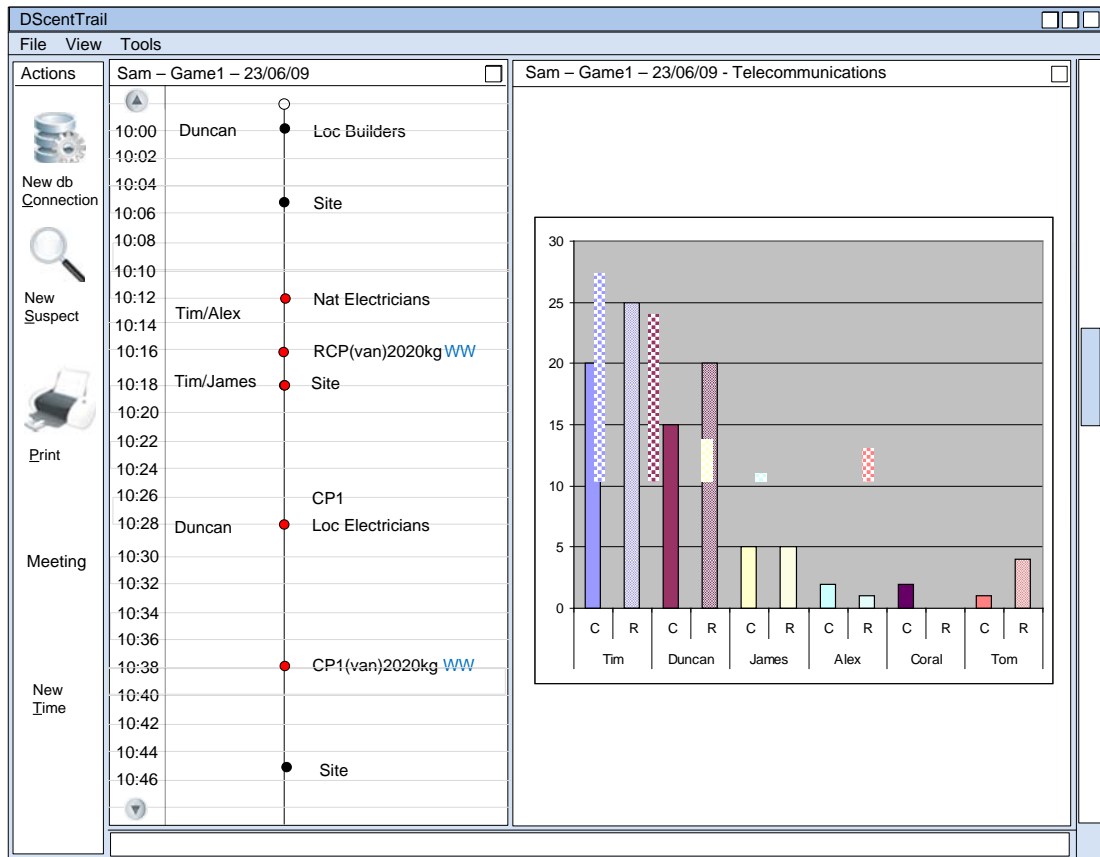

Figure 6.3 - DScentTrail screen design (Game Summary of Telecommunications Activity)

6.1.2 Technical System Design

The DScentTrail System is an Object Oriented (Ambler 2009) (OO) system, designed with the use of UML (Booch 2005) diagrams. The game data was captured and stored in an Oracle Spatial database (Oracle Corporation 2010) by a partnering university. There were many tables in this database, though the ones significant to the DScentTrail system are shown in figure 4.3. The DScentTrail system connected to this Oracle database using the Java Database Connectivity (JDBC) API (Reece 2000). The various class and object models created can be seen in the sections below.

6.1.2.1 DScent.Model Class Model

dscent.model Class Model

This is the UML class model which shows the main classes used to store the underlying data for the dscentral software.

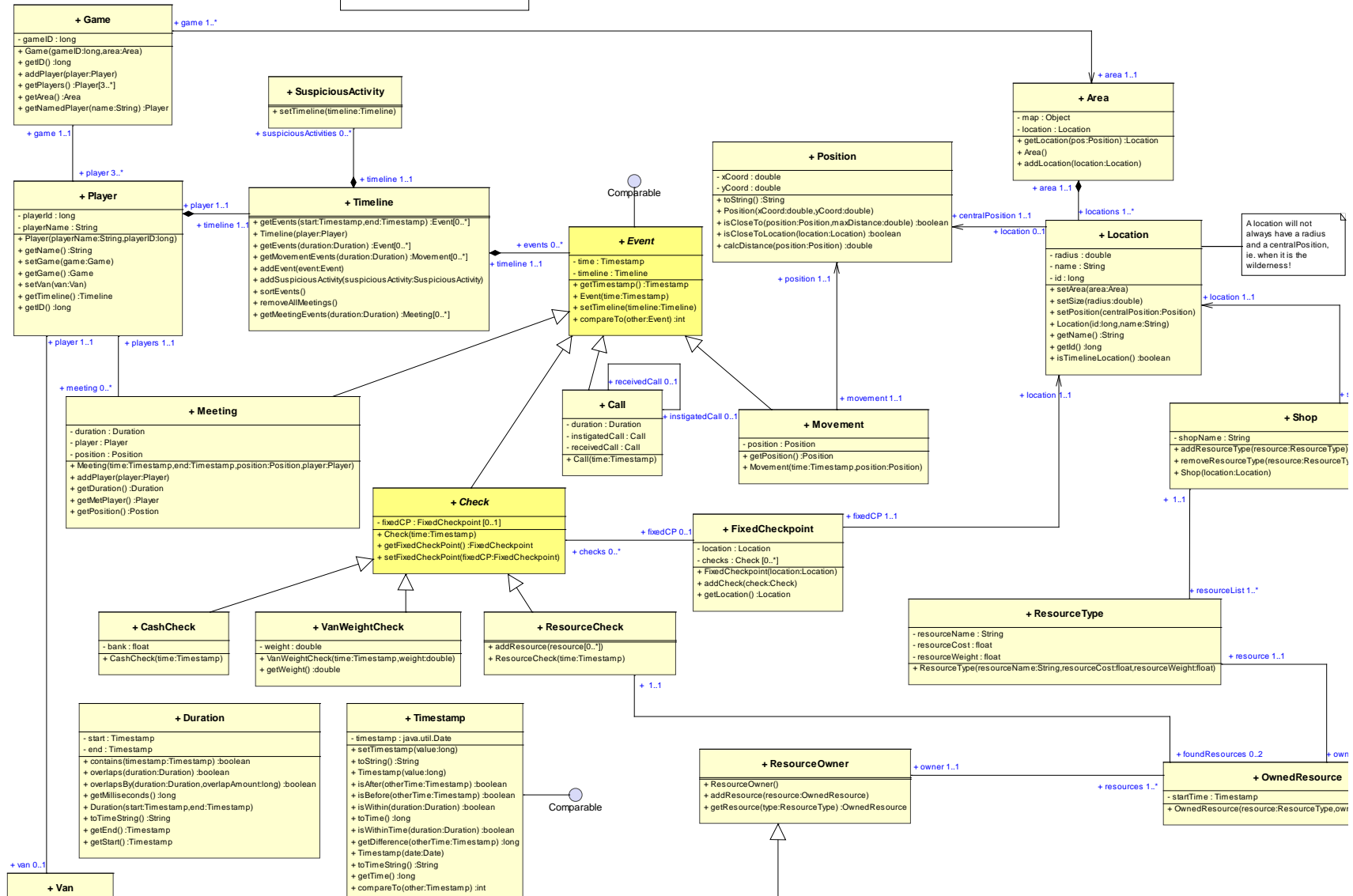

6.1.2.3 GUI DScentTrail Main Window (Object Model)

GUI DScentTrail Main Window (Object Model)

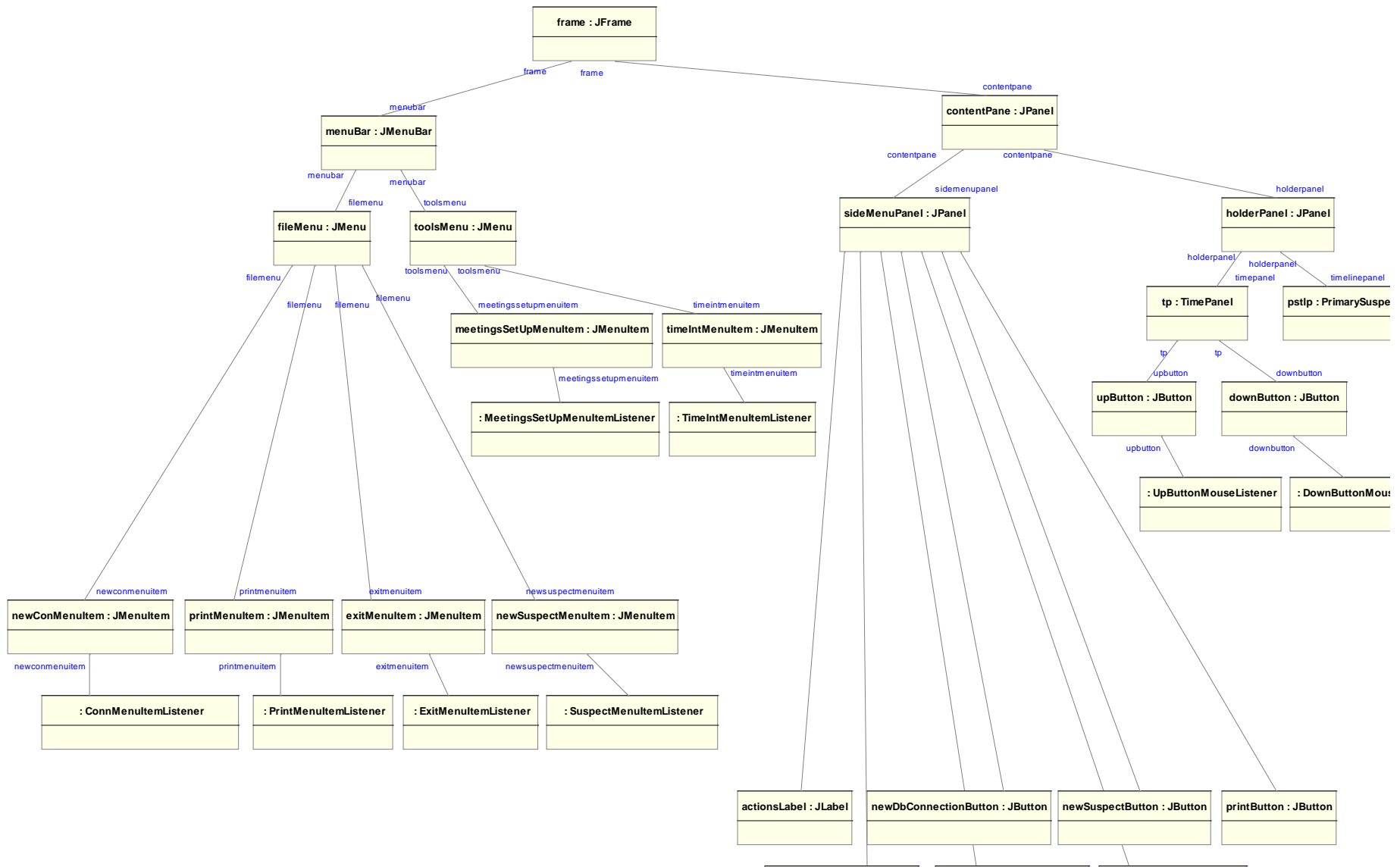

6.1.2.4 GUI Database Connection (Object Model)

GUI DB Connection Dialog (Object Model)

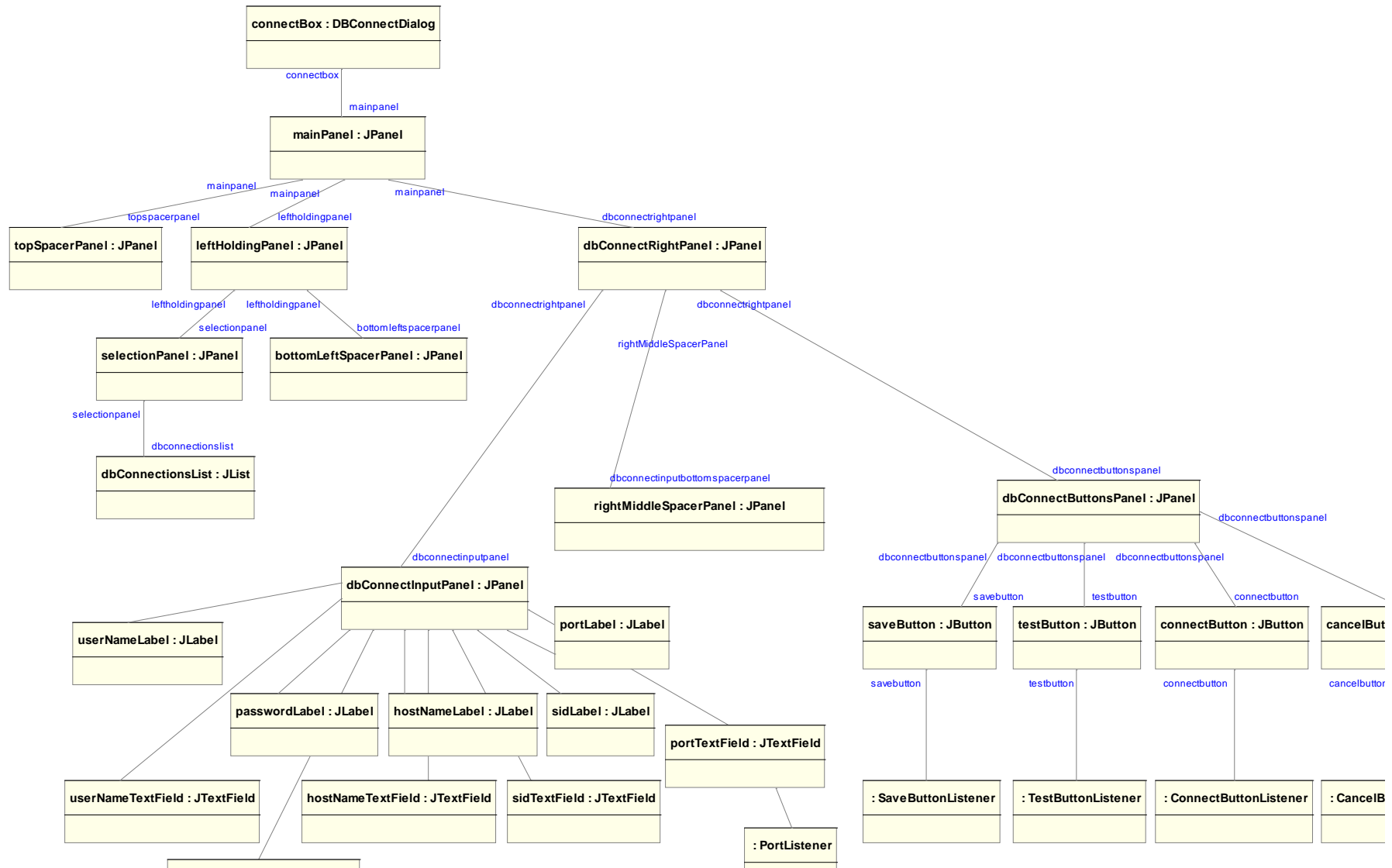

6.1.2.5 GUI New Suspect (Object Model)

GUI New Suspect Dialog (Object Model)

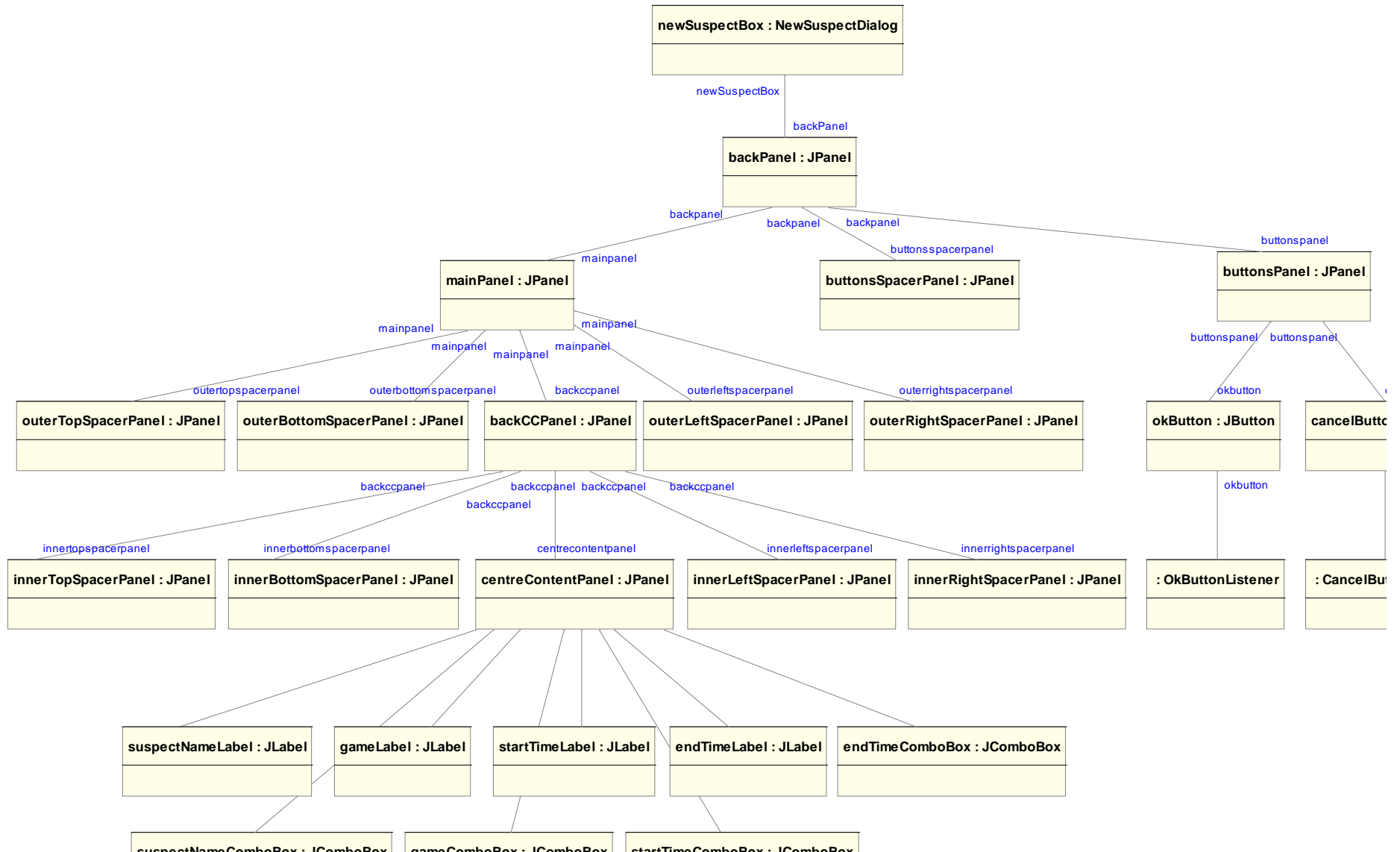

6.1.2.6 GUI Meetings Set Up (Object Model)

GUI Meetings Set Up (Object Model)

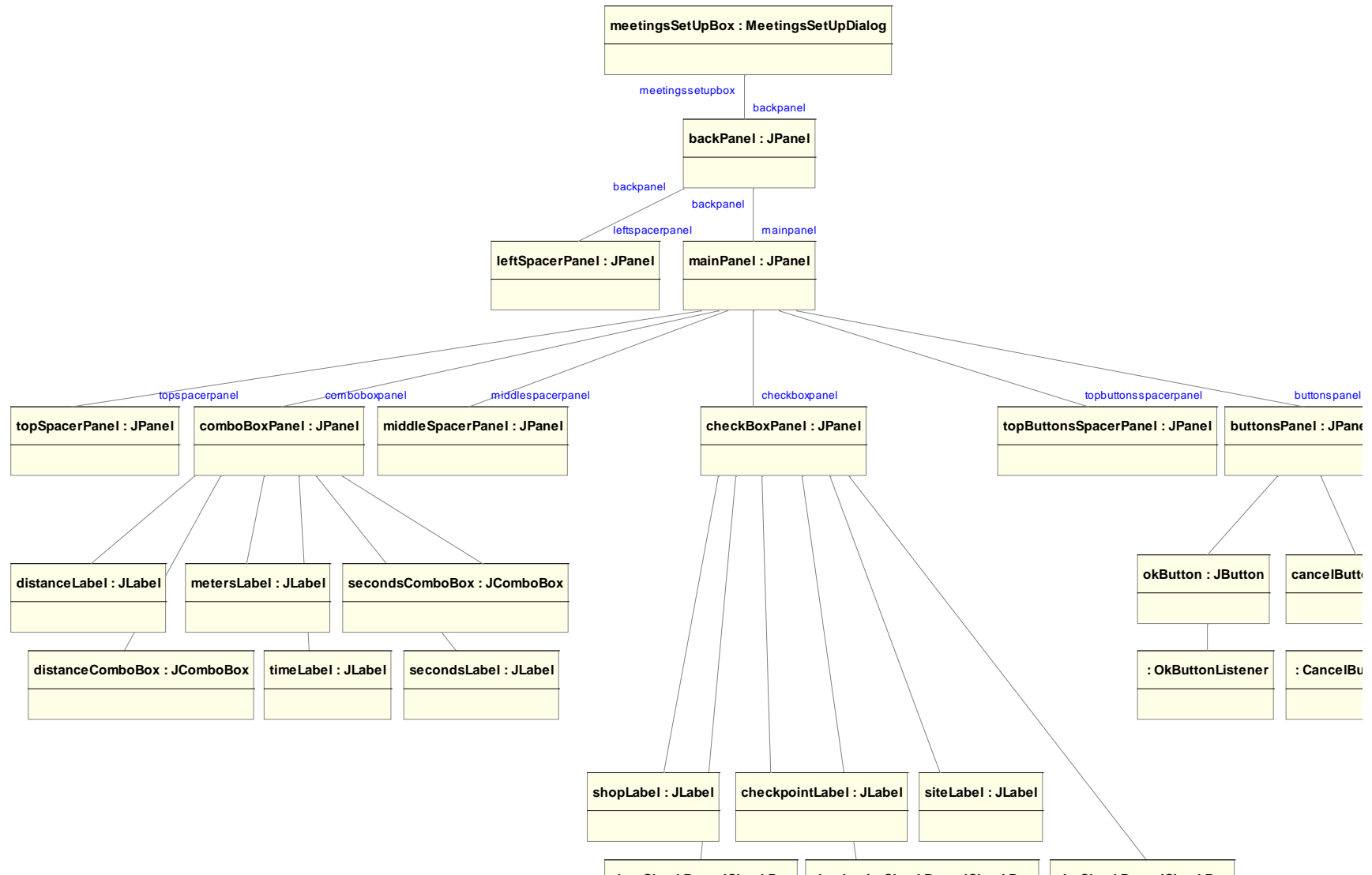

6.1.2.7 GUI Time Interval Set Up (Object Model)

GUI Time Interval Set Up Dialog (Object Model)

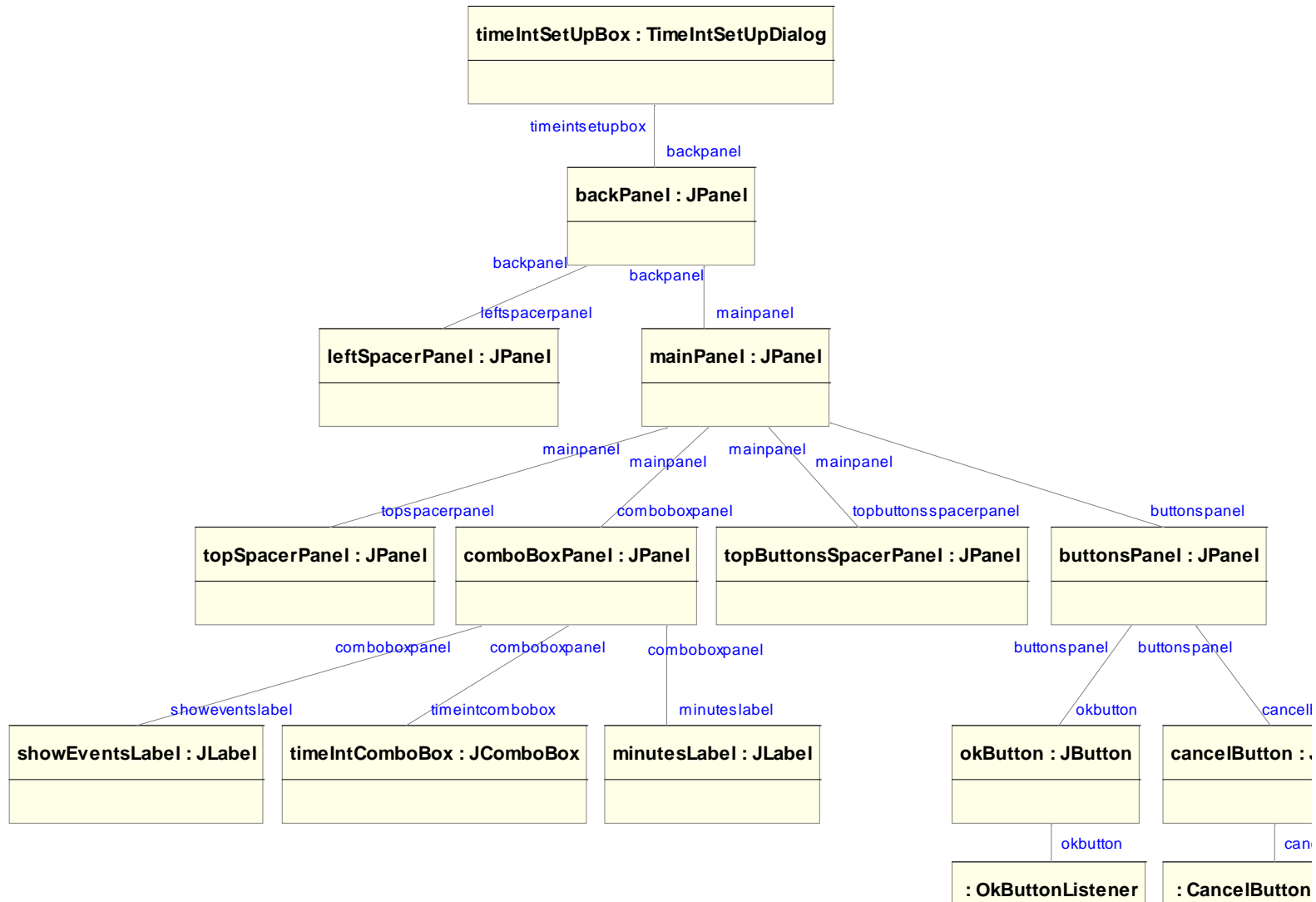

6.1.3 Screen Shots

It was never the intention to implement the entire design for DScentTrail as this would not have been achievable within the timeframe and with the allocated resources. However, all major areas were implemented, this allowed for the data to be imported from an external non-tailored database and a dynamic *intelligent* class model built (see section 6.1.2.1), from this meaningful information could be drawn. Various screen shots from the sections implemented can be seen in the sections below. Implementation included building and integrating a neural network to show deceptive scent trails for a suspect.

6.1.3.1 New Database Connection

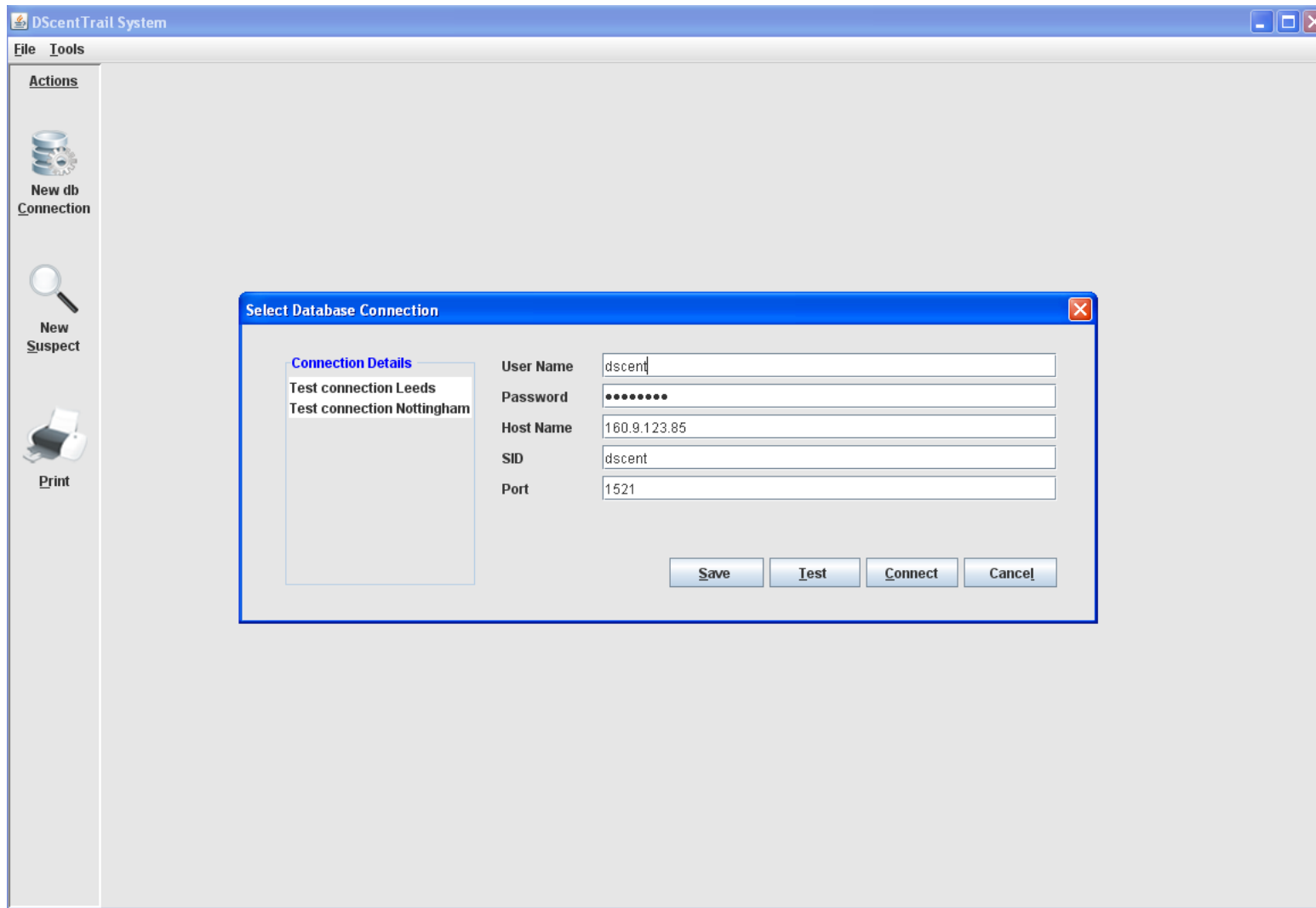

6.1.3.2 New Primary Suspect

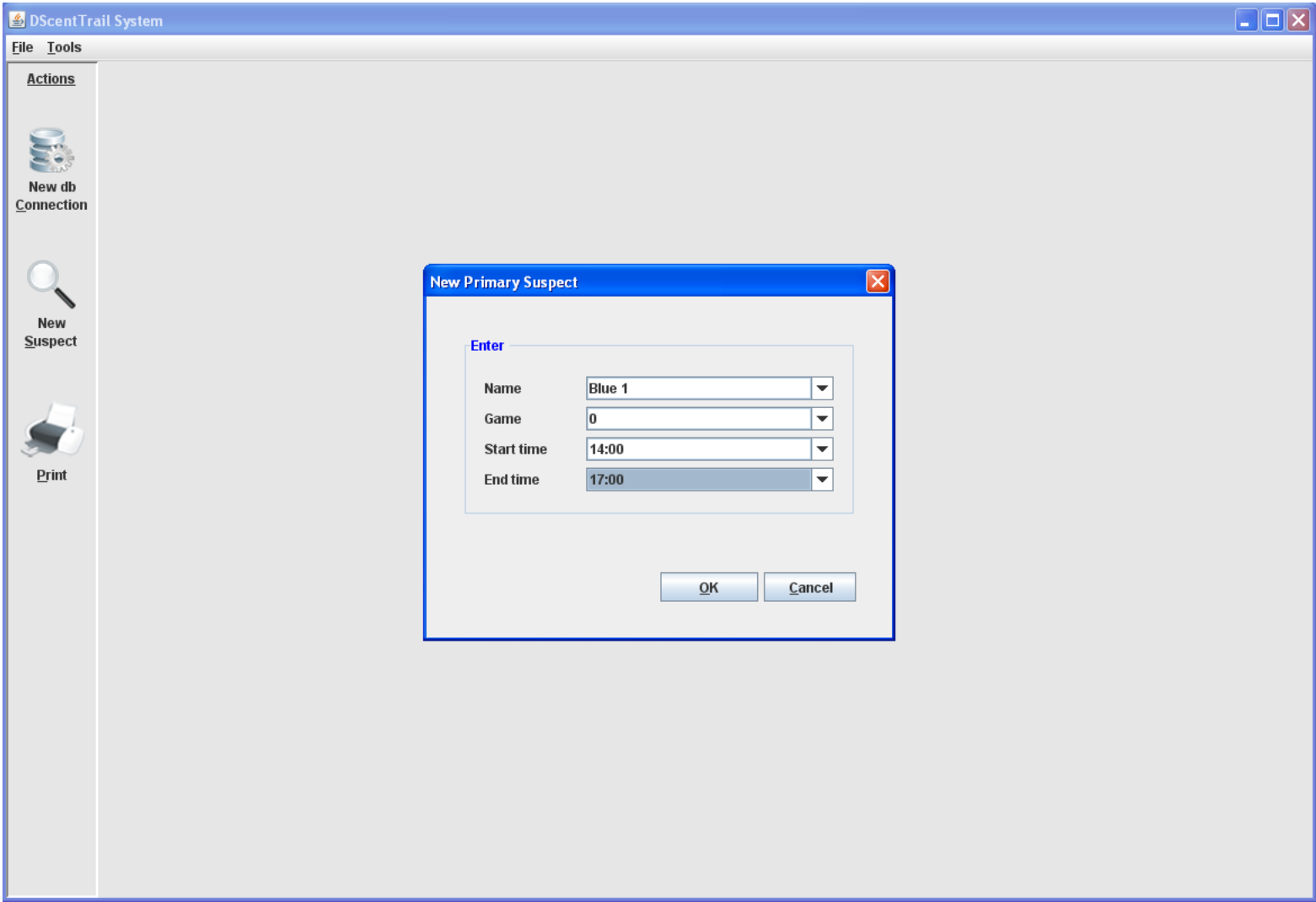

6.1.3.3 Meetings Configuration

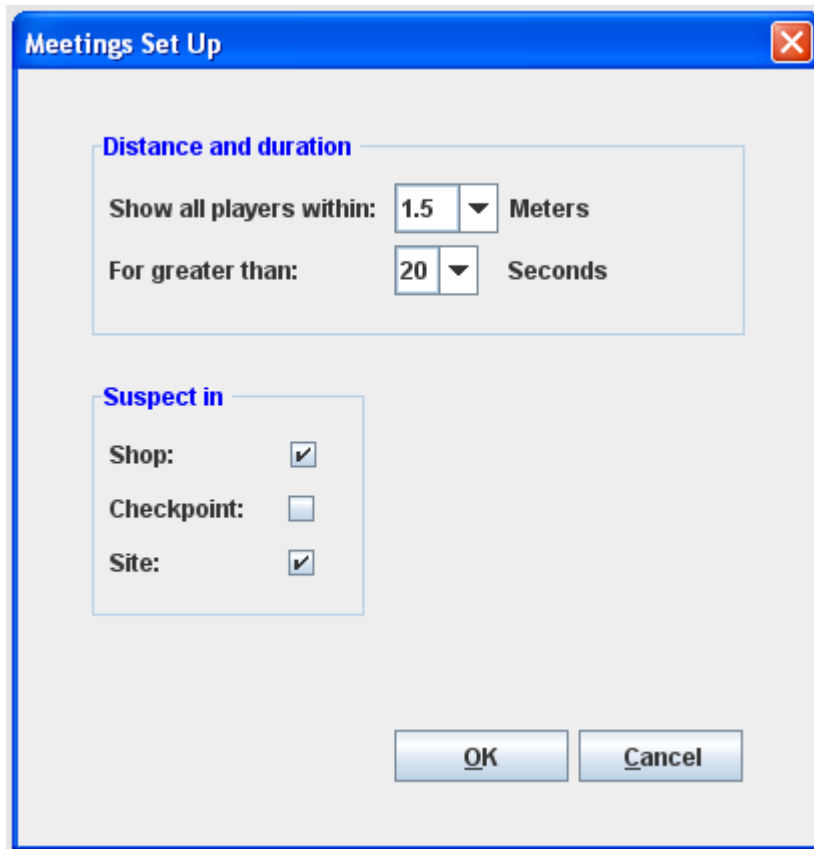

The image shows a 'Meetings Set Up' dialog box with a blue title bar and a close button (X) in the top right corner. The dialog is divided into two main sections: 'Distance and duration' and 'Suspect in'. The 'Distance and duration' section contains two rows of controls: 'Show all players within:' with a numeric input field set to '1.5' and a dropdown arrow, followed by the text 'Meters'; and 'For greater than:' with a numeric input field set to '20' and a dropdown arrow, followed by the text 'Seconds'. The 'Suspect in' section contains three rows of controls: 'Shop:' with a checked checkbox, 'Checkpoint:' with an unchecked checkbox, and 'Site:' with a checked checkbox. At the bottom of the dialog are two buttons: 'OK' and 'Cancel'.

Meetings Set Up

Distance and duration

Show all players within: 1.5 Meters

For greater than: 20 Seconds

Suspect in

Shop:

Checkpoint:

Site:

OK Cancel

6.1.3.4 Time Interval Configuration

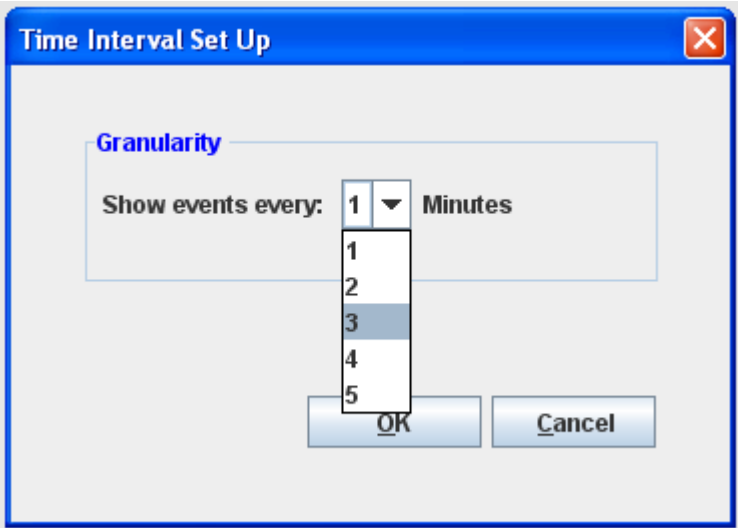

6.1.3.5 Primary Suspect Timeline Showing Non-deceptive Behaviour

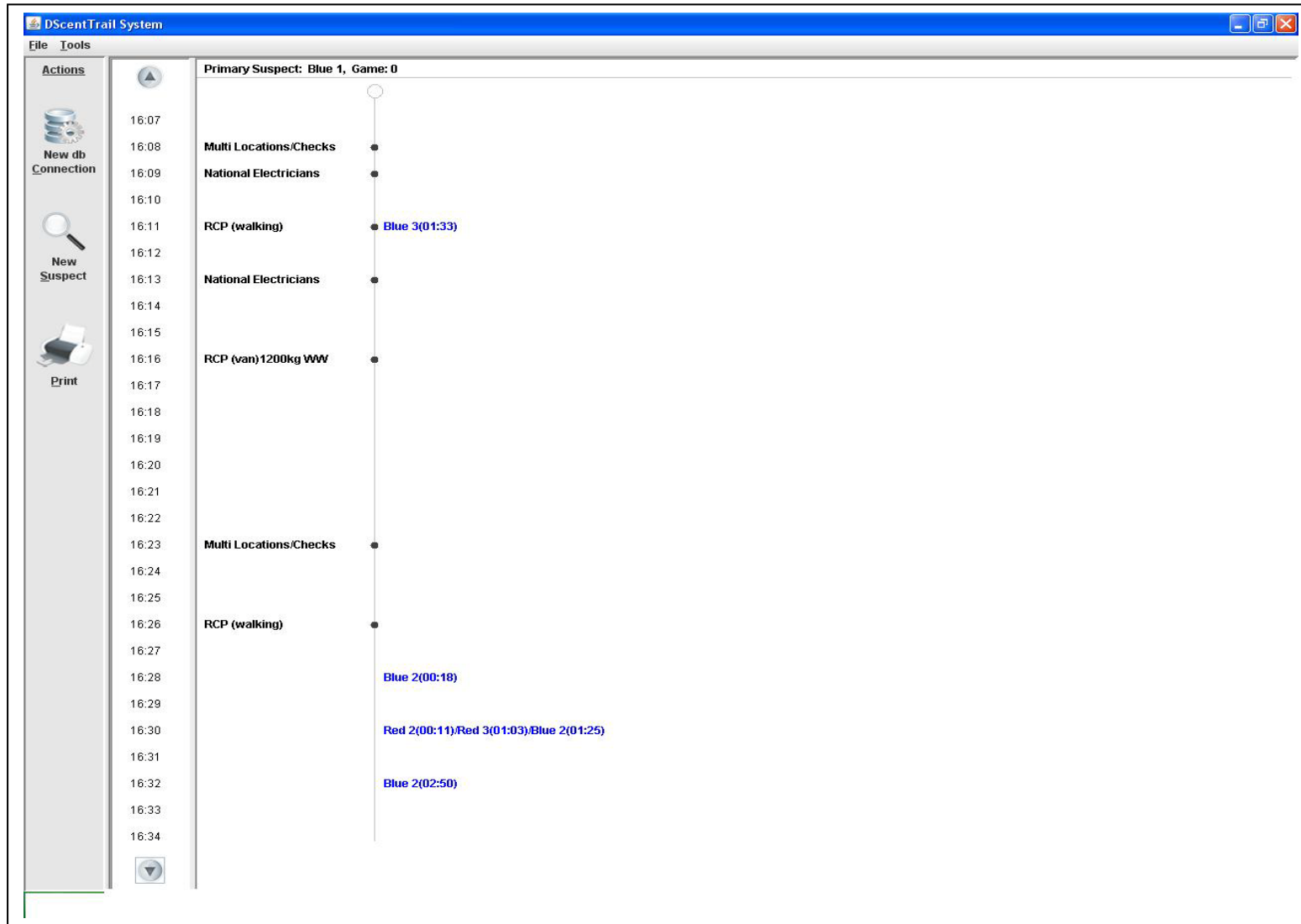

6.1.3.6 Primary Suspect Timeline Showing Deceptive Behaviour

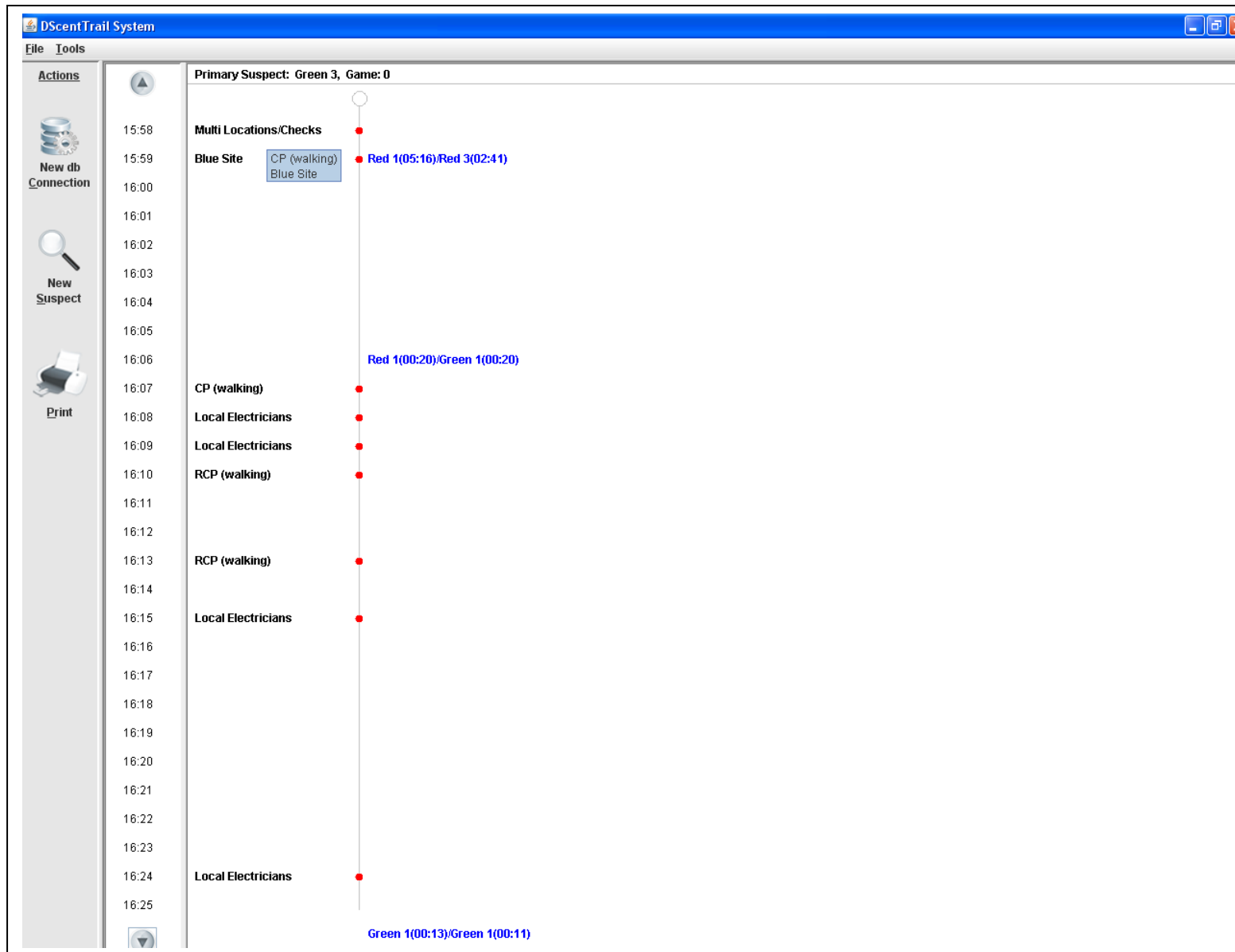

6.2 Artificial Intelligence (AI)

The intention was to build two AI modules running in parallel, both attempting to identify deceptive behaviour. The two AI techniques chosen would be completely different, both working independently, attempting to identify deceptive behaviour. The output from each technology would be compared and combined into a hybrid AI module system to strengthen the accuracy of their results, before drawing the investigators attention within the DScentTrail system to possible deception.

Unfortunately, only two games worth of data was available during the development of this phase. This resulted in the neural network not being trained or tested and the behavioural based AI module not being built. Both systems, in effect, being significantly affected by data sparseness issues: a situation analogous to expecting expert solutions from someone who has never been able to study the problem.

If a suitable amount of data had been forthcoming at an appropriately early phase of the project, this would have enabled the planned systems development, modelling and subsequent analysis to be conducted within the time-frame of the project. However, the first 2 games data only arrived at the end of the project's second year and a following 9 games were sent to us 1 year later. None of these games included telecommunications data and due to the majority of the game data arriving two months prior to the end of the project (taking holidays into account) and therefore no useful time was available for our team to attempt the modelling and analysis required. It is submitted that our methods and concepts are robust but the course of events and available data combined to confound.

6.2.1 Neural Network

As the neural network architecture used in phase one was so successful given the amount of data, it was the intention to use the same for phase two. However, this was not possible, given the increased number of variables in the game. A regression network architecture (Ripley 2008) was therefore adopted which takes the output from the previous row of input data and uses this as input with the next. This allows the network to see time series data as opposed to discrete chunks of data. The problem with chunking the data is that there is no distinct point at which to do this, other than to present a complete trail. Presenting a complete trail was not practical in this case as the network would become far too complex to successfully train. By contrast a regression neural network takes a subset of inputs and the complete trail is then passed through the inputs, rather like a person viewing the trail an element at a time whilst retaining a memory of what they have previously seen and forming an opinion based on potentially increasing evidence. A trail is passed to the neural network an element at a time and for each presentation it outputs a certainty that the trail contains suspicious behaviour. For a genuinely suspicious trail the neural network would output a steadily

strengthening certainty as it is presented with more data. This process is transparent to the DScentTrail system, all the user would see would be a final output from the neural network. This neural network was integrated with the DScentTrail system, potentially deceptive scent trails were then highlighted for the investigator's attention.

The neural network was developed using Encog (Heaton 2010), which is a more powerful neural network and artificial intelligence application programmers interface (API) than JOONE, used for the phase 1 neural network. The neural network architecture used was an Elman Recurrent Network (Elman 1991). The Java code can be seen in Appendix H.1 and the architecture diagram can be seen in figure 6.4 below.

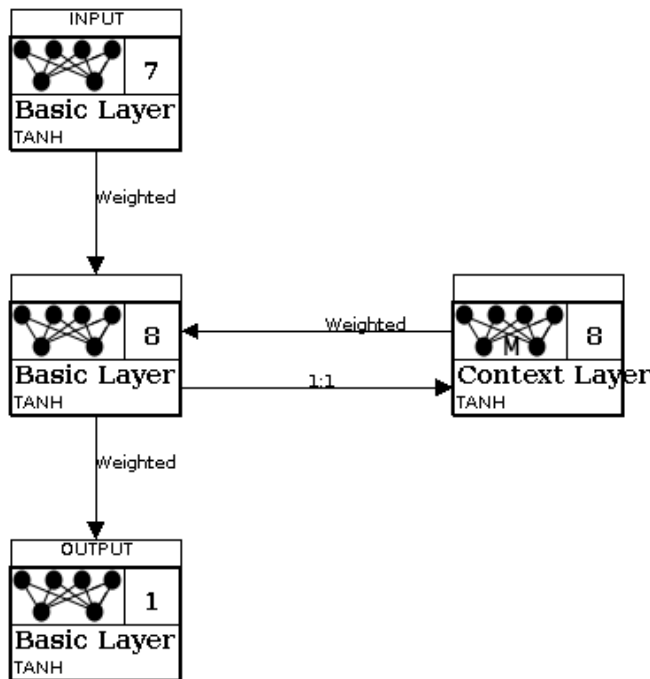

Figure 6.4 – Neural Network Architecture

Due to the severe lack of data available, it proved impossible to train the network. Though a regression neural network was implemented and integrated into the DScentTrail system. Future work is underway to develop a method for generating behavioural data, building on the rules of the location based game. This will be done by combining intelligent agents²⁴ with gene expression programming²⁵ and the use of an Emdros database²⁶. The intention is to train and fully test the neural network on the receipt of this game data.

6.2.1.1 Neural Network Input File

As there was so little data to train and test the neural network, the number of variable had to be reduced to a bare minimum. The resulting columns were as follows:

Event, Time, Items, Award, CallDuration, CallLocation, CallCount, ClosePlayers

The Gameld, PlayerId and Time will be present for all rows, but not shown to the neural network. A player's worth of data for a game was shown to the network in time order. A description of the input file is shown in table 6.2 below and an example of an input file for Game 0, Player 1 can be seen in table 6.3.

Event	Description	Associated Column(s) for Event	Column Explanation
0	Entered wilderness	ClosePlayers	Close Players = the number of players within 2 meters for greater than 10 seconds from the player entered a location to the time they left.
2	Entered Local Builders	ClosePlayers	Direct Path = Boolean, whether the player travelled directly to this location (from the previous) or in a random fashion. First Location of the game is assumed to be direct.
3	Entered Nat. Builders	ClosePlayers	
4	Entered Local Electrical Store	ClosePlayers	
5	Entered Nat. Electrical Store	ClosePlayers	
6	Entered Red Site	ClosePlayers	
7	Entered Blue Site	ClosePlayers	
8	Entered Green Site	ClosePlayers	
9	Entered Yellow Site	ClosePlayers	
10	Entered Fixed Checkpoint	Items, Award, ClosePlayers	Items: 0 = Not Applicable (walking - no van) 1 = 1 x Wiring 2 = 1 x Dynamite 3 = 1 x Construction 4 = 1 x Soil 5 = 1 x Fertiliser 6 = 2 x Wiring 7 = 2 x Dynamite 8 = 2 x Construction 9 = 2 x Soil 10 = 2 x Fertiliser 11 = 1 x Wiring + 1 x Dynamite 12 = 1 x Wiring + 1 x Construction 13 = 1 x Wiring + 1 x Soil 14 = 1 x Wiring + 1 x Fertiliser 15 = 1 x Dynamite + 1 x Construction 16 = 1 x Dynamite + 1 x Soil 17 = 1 x Dynamite + 1 x Fertiliser 18 = 1 x Construction + 1 x Soil

			19 = 1 x Construction + 1 x Fertiliser 20 = Nothing in van Award: 0 = non-checkpoint related value, 1 = -£500, 2 = £50, 3 = £100
13	Random Checkpoint	Items, Award	
14	Call Made	CallDuration, CallCount, CallLocation	CallCount = total number of calls made/received to/from same player throughout the game.
15	Call Received	CallDuration, CallCount, CallLocation	CallLocation = the location of the player when the call was made or received (Checkpoints are grouped together as Location 10).

Table 6.2 Neural Network Input File Column Description Table

GameId	PlayerId	Event	Time	Items	Award	CallDuration	CallLocation	CallCount	ClosePlayers
0	1	7	849						
0	1	15	850			19	0	4	
0	1	0	858						
0	1	5	906						3
0	1	15	1257			10	5	1	
0	1	0	1267						
0	1	10	1351	0	2				
0	1	0	1375						
0	1	6	1439						2
0	1	0	1514						
0	1	7	1527						
0	1	0	1536						
0	1	10	1556	0	2				
0	1	0	1587						
0	1	10	1699	0	2				
0	1	0	1710						
0	1	9	1765						
0	1	15	1777			4	9	4	
0	1	0	1786						
0	1	10	1809	0	2				
0	1	0	1816						
0	1	6	1838						1
0	1	0	2132						
0	1	7	2154						
0	1	0	2167						
0	1	10	2220	0	2				
0	1	0	2230						
0	1	6	2324						3
0	1	15	2866			8	6	4	
0	1	0	3094						2
0	1	8	3159						1
0	1	0	3179						
0	1	6	3196						
0	1	0	3231						
0	1	9	3241						
0	1	0	3242						2
0	1	10	3339	0	2				
0	1	0	3397						
0	1	10	3456	0	2				
0	1	0	3482						1
0	1	5	3616						
0	1	0	3656						

0	1	10	3712	0	2				
0	1	0	3734						
0	1	6	3800						1
0	1	0	3839						
0	1	7	3845						
0	1	0	3854						
0	1	10	3870	0	2				2
0	1	0	4005						
0	1	10	4156	0	2				
0	1	0	4168						
0	1	3	4189						1
0	1	0	4255						
0	1	15	4294			8	0	4	
0	1	4	4321						2
0	1	0	4528						
0	1	10	4553	0	2				
0	1	0	4570						

Table 6.3 - Input file for Game 0, Player 1

6.2.2 Behavioural Based Artificial Intelligence

Phase two incorporated the preliminary stages of design for a symbolic AI (Haugeland 1985) system, here the decision making process behind the output was visible to the investigators; this was in direct contrast to the 'black box' nature of the neural network. By analysing the relationships of the variables within the game, patterns and behavioural rules could be extracted and type classifications derived. These models would then be embedded, attached with probabilistic information to identify emergent deceptive behaviour. This would become a refining, iterative process for future research and development.

6.2.2.1 Theme 5.0

Theme 5.0 software (Noldus Information Technology 2004) was used for detecting and analysing hidden patterns of behaviour within the game data. Theme detects statistically significant time patterns in sequences of behaviour and provides basic analysis tools. This behavioural based AI module would contain probabilistic information and would be centred on pattern matching and relationship modelling of entities within their environment. Two files are required to analyse data using Theme software; a category table (see Appendix H) and a data file (see Appendix I). The category table contains coded metadata used to record the subject (participants); the behaviours (events) and the modifiers (variables), see table 6.4 for more details. Mutual exclusivity between the three is enforced within this file. The data file contains behavioural data, scored according to the codes defined in the category table. Separate data files were required for each participant resulting in 21 for analysis purposes.

Analysis was performed on full game and individual team game data. When entire game data was analysed Theme detected over 170 patterns. Due to

the nature of the game; each player being part of a three person team there was no disadvantage in splitting the analysis down into teams, this resulted in more manageable data sets and subsequently a simplified analysis process. The results were analysed using both temporal and event based analysis.

Subject	Behaviour	Modifier
01-21	initialmovement	directyes
01-21	wilderness	
01-21	localbuilders	directyes, directno
01-21	nationalbuilders	directyes, directno
01-21	localelectricians	directyes, directno
01-21	nationalelectricians	directyes, directno
01-21	redsite	directyes, directno
01-21	bluesite	directyes, directno
01-21	greensite	directyes, directno
01-21	yellowsite	directyes, directno
01-21	checkpoint1	directyes, directno
01-21	checkpoint2	directyes, directno
01-21	checkpoint3	directyes, directno
01-21	initialmobiledevice	
01-21	nomdaction	
01-21	incomingcall	01-21
01-21	outgoingcall	01-21
01-21	vanweigh	0,200,250,400,450,500,600,650,700,800,900,950,1000,1050,1200,1250,1400,1450,1500,1600,1650,1700,1750,1800,1900,1950,2000,2200,2250,5000,
01-21	reveal	Noitems,1wiring,1dynamite,1construction,1soil,1fertiliser,2wiring,2dynamite,2construction,2soil,2fertiliser,1wiring1dynamite,1wiring1construction,1wiring1soil,1wiring1fertiliser,1dynamite1construction,1dynamite1soil,1dynamite1fertiliser,1construction1soil,1construction1fertiliser,walk
01-21	nomeetingpnaction	
01-21	meetpn	

Table 6.4 – Category Table element relationships

6.2.2.1.1 Temporal Analysis of Results

Theme detected a total of 329 patterns over the two games by setting the following search parameters: “Minimum Occurrences = 3”; “Significance Level = 0.0005” and “Exclude Frequent Event Types = Yes”. Due to the simplicity of the game rules, Theme did not identify any patterns which the development team were not already aware, though it did serve as confirmation. It was apparent that by identifying these patterns Theme recognised the individual teams, which would be extremely significant in a more complex system outside the constraints of the game. Theme provides various ways of viewing pattern information; figure 6.5 shows a Pattern Length Distribution graph giving an overview of patterns grouped by their number of internal elements. The event time plot scatter graphs were of little use as the ordering of the events could not be controlled.

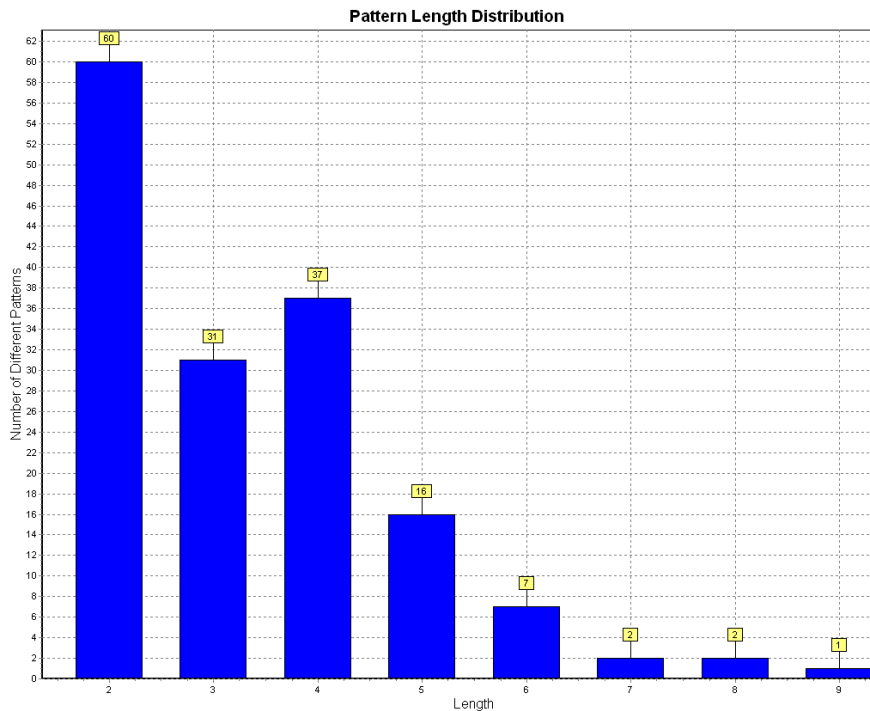

Figure 6.5 – Theme: Pattern Length Distribution graph

From here the individual length categories were considered by viewing the individual pattern diagrams, an example of which can be seen in figure 6.6:

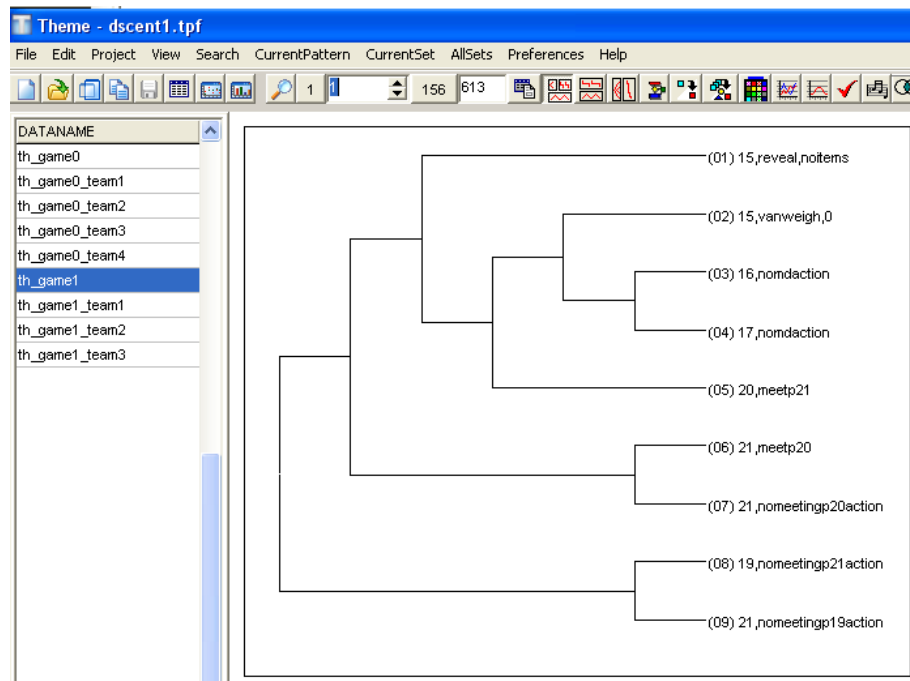

Figure 6.6 – Theme: Pattern Diagram

Once relevant patterns had been identified, it was then important to know how many of each relevant pattern had been identified. To do this it was

necessary to view the data using the Current Pattern Statistics view shown in figure 6.7:

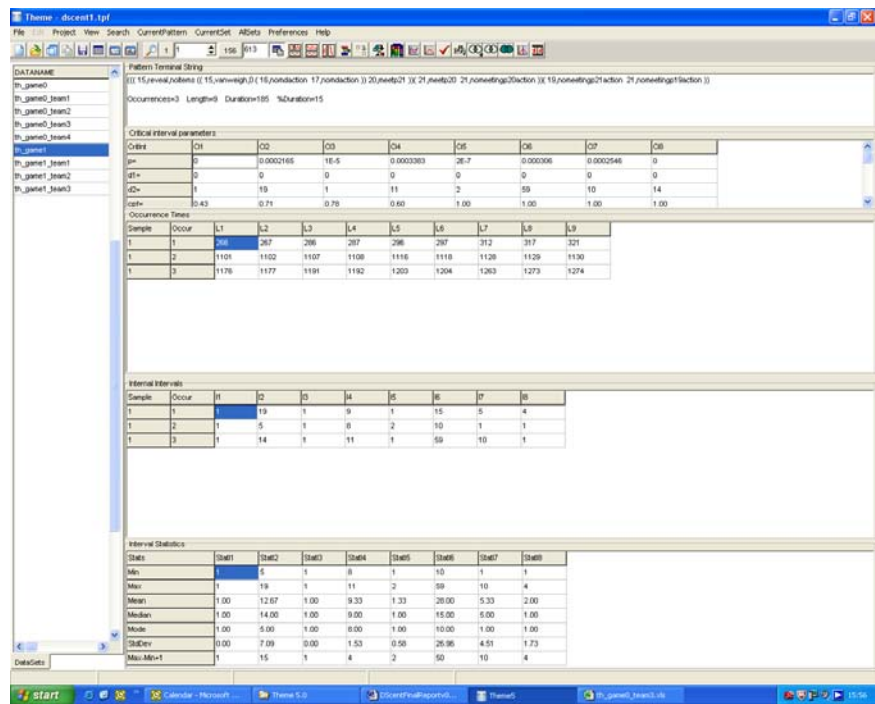

Figure 6.7 – Theme: Current Pattern Statistics

6.2.2.1.2 Event Based Analysis of Results

Key events with their average number of occurrences were identified and calculated for each of the three players within a team, before calculating team averages. The totals were then considered to see whether any teams were behaving differently to others, i.e. differences between the building and the terrorist teams. Numbers were highlighted to indicate significant variants which required further analysis: see figure 6.8 for more details where the final three columns are the averages of the sums of Building Team 1: P13, 14 and 15, Building Team 2: P19, 20 and 21 and of Terrorist Team 1: P16, 17 and 18. The figures highlighted in red and blue indicates significant variants which required further analysis. Alternative categorisation scenarios were analysed but with the sparse amount of data available, no significant patterns were detectable for identifying deceptive behaviour. The following results were drawn from this analysis:

1. Visits to Checkpoint1 and the National Electricians were higher with the terrorist team, this was because the building teams were spreading their visits between the electrical and building stores to purchase what they needed for their building tasks, whereas the terrorist teams had the option of buying all their items from just the electrical stores. Checkpoint1 was on route to the National Electricians; see figure 1 for details.

- The National Builders and Checkpoint3 were visited much less with the terrorist team, this again was because the terrorist teams did not need to visit the building stores. Checkpoint3 was on route to the National Builders and therefore was visited far less by the terrorist team.

By performing the above analysis process; particularly with more complex data, key events and combinations could be identified and from these combinations, the rules and intelligence of the system could start to be derived.

	P13 (B)	P14 (B)	P15 (B)	P16 (T)	P17 (T)	P18 (T)	P19 (B)	P20 (B)	P21 (B)	(B1)	(B2)	(T1)
checkpoint1	4	3	4	3	4	8	3	5	2	3.7	3.3	5.0
checkpoint2	7	7	7	5	7	11	4	7	10	7.0	7.0	7.7
checkpoint3	3	6	2	2	1	1	6	4	2	3.7	4.0	1.3
randomcheck	0	1	5	3	1	0	0	1	3	2.0	1.3	1.3
reveal,walk	11	10	1	3	4	17	11	4	4	7.3	6.3	8.0
reveal,noitems	0	2	7	2	2	0	0	6	3	3.0	3.0	1.3
reveal,1wiring	0	0	0	0	0	0	0	0	2	0.0	0.7	0.0
reveal,1dynamite	0	0	0	0	1	0	0	0	0	0.0	0.0	0.3
reveal,1construction	0	0	2	0	0	0	0	0	0	0.7	0.0	0.0
reveal,2wiring	0	0	1	3	0	0	0	0	0	0.3	0.0	1.0
reveal,2dynamite	0	0	0	0	0	0	0	2	0	0.0	0.7	0.0
reveal,1wiring1dynamite	0	0	2	0	0	0	0	0	0	0.7	0.0	0.0
reveal,1soil1fertiliser	0	0	1	0	0	0	0	0	1	0.3	0.3	0.0
vanweigh,0	1	2	7	2	2	0	0	6	3	3.3	3.0	1.3
vanweigh,200	0	0	0	0	1	0	0	0	2	0.0	0.7	0.3
vanweigh,400	0	0	0	1	0	0	0	0	0	0.0	0.0	0.3
vanweigh,600	0	0	2	0	0	0	0	2	0	0.7	0.7	0.0
vanweigh,800	0	0	0	1	0	0	0	0	0	0.0	0.0	0.3
vanweigh,1000	0	0	3	1	0	0	0	0	0	1.0	0.0	0.3
vanweigh,1250	0	0	1	0	0	0	0	0	0	0.3	0.0	0.0
vanweigh,1750	0	0	0	0	0	0	0	0	1	0.0	0.3	0.0
wilderness	25	30	39	24	30	31	26	40	32	31.3	32.7	28.3
redsite	3	5	6	1	0	0	0	0	0	4.7	0.0	0.3
yellowsite	1	0	1	0	2	2	3	8	8	0.7	6.3	1.3
bluesite	3	5	6	9	10	7	3	3	1	4.7	2.3	8.7
greensite	0	2	1	0	0	0	4	6	2	1.0	4.0	0.0
localelectricians	1	0	1	2	2	1	0	0	2	0.7	0.7	1.7
localbuilders	1	0	4	0	0	0	0	1	0	1.7	0.3	0.0
nationalbuilders	0	2	5	0	0	0	2	4	3	2.3	3.0	0.0
nationalelectricians	0	0	2	2	4	1	1	2	2	0.7	1.7	2.3
meetp13	0	4	5	1	1	0	0	0	1	3.0	0.3	0.7
meetp14	4	0	3	3	1	0	0	0	0	2.3	0.0	1.3
meetp15	3	3	0	5	5	1	2	0	0	2.0	0.7	3.7
meetp16	1	3	5	0	6	8	1	2	1	3.0	1.3	4.7
meetp17	0	1	5	4	0	4	2	1	2	2.0	1.7	2.7
meetp18	0	0	1	7	4	0	1	1	1	0.3	1.0	3.7
meetp19	0	0	2	0	2	1	0	8	11	0.7	6.3	1.0
meetp20	0	0	0	1	1	1	8	0	7	0.0	5.0	1.0
meetp21	0	0	0	0	2	1	11	7	0	0.0	6.0	1.0
incomingcall,13	0	2	2	2	1	0	0	0	0	1.3	0.0	1.0

incomingcall,14	1	0	1	0	0	0	0	0	0	0.7	0.0	0.0
incomingcall,15	2	1	0	0	0	0	0	0	0	1.0	0.0	0.0
incomingcall,16	0	0	0	0	2	0	0	0	0	0.0	0.0	0.7
incomingcall,17	0	0	0	5	0	4	0	0	0	0.0	0.0	3.0
incomingcall,18	0	0	0	0	1	0	0	0	0	0.0	0.0	0.3
incomingcall,19	0	0	0	0	0	0	0	0	1	0.0	0.3	0.0
incomingcall,20	0	0	0	0	0	0	0	0	4	0.0	1.3	0.0
incomingcall_21	1	1	0	0	0	0	4	6	0	0.7	3.3	0.0
outgoingcall,13	0	1	1	0	0	0	0	0	1	0.7	0.3	0.0
outgoingcall,14	2	0	1	0	0	0	0	0	1	1.0	0.3	0.0
outgoingcall,15	2	1	0	0	0	0	0	0	0	1.0	0.0	0.0
outgoingcall,16	2	0	0	0	5	0	0	0	0	0.7	0.0	1.7
outgoingcall,17	1	0	0	2	0	1	0	0	0	0.3	0.0	1.0
outgoingcall,18	0	0	0	0	4	0	0	0	0	0.0	0.0	1.3
outgoingcall,19	0	0	0	0	0	0	0	0	4	0.0	1.3	0.0
outgoingcall,20	0	0	0	0	0	0	0	0	6	0.0	2.0	0.0
outgoingcall,21	0	0	0	0	0	1	0	4	0	0.0	1.3	0.3

Figure 6.8 – Event Based Analysis

6.2.2.2 Behavioural Based AI Conclusions

It was envisaged that by performing the above analysis, key events and combinations of events would be identified and from this the rules and intelligence of the system derived. However, due to the basic nature of the game rules and as so little data was available, of which the telecommunications were contrived, the analysis techniques merely confirmed the results already known by the development team. This analysis did however prove that Theme was capable of identifying groups within the game data and therefore would be extremely useful in the real world with more complex data.

7. Conclusions

DScenTrail presents a new way of viewing deceptive behaviour both by individuals and by groups. The system proved to be extremely effective when studied by psychologists and experts in the field of interrogation and serious crime investigation. The AI modules working to identify deception would provide DScenTrail with intelligent information attracting the investigator's attention to a subset of potential terrorist suspects. Future work would include separating the scent trail information into chunks and training the neural network to identify deceptive patterns within a scent trail; which would be necessary when used in the real world.

One of the largest problems encountered by the development team was the lack of game data available. Though it was initially intended to be more, the final amount of Location Based game data which arrived in time for development and subsequently analysis was two games, of which the vitally

important communications element was missing. Two games worth of data is not enough to train and test an AI system.

Meeting the dual requirement of making the location based game playable while enabling it to generate suitable data for all the various analysis required on the project proved not possible within the timeframe. The cognitive load placed on the participants for the location based game was much higher than for the original board game. In addition the participants had less time to think because with the location based game participants played continuously rather than waiting for their throw of a dice. This resulted in the data from the board game being much richer than the location based game, by which is meant containing greater variations in strategies of play. The software development effort required for programming the mobile devices was greatly underestimated resulting in incomplete and unreliable data for system testing purposes.

Designing a game capable of generating data, useful for both AI and forensic psychology proved to be problematic. There were many changes which would have made the data more suited to testing the accuracy of AI systems. Most of these ideas involved adding extra complexity and noise to the rules, for example, allowing players to buy from a larger selection of shops, having potentially secret meeting places where players thought they would not be seen, and in general just making the game rules closer to real life. These changes were not incorporated as they conflicted with the requirements of the forensic psychologists. In retrospect, more time should have been spent designing the rules of the game to suit all parties or different rules should have been designed for each separate research discipline.

Many of the observations above suggest that it is very difficult, if not impossible to generate suitably complex data via game playing. Future work is currently underway to develop a method for automatically generating behavioural data, building on the rules of the location based game. Research is being carried out which combines intelligent agents (Evertsz 2009) with gene expression programming (Ferreira 2006), an Emdros database (Petersen 2004) is also being considered.

A tentative conclusion drawn from the analysis is that the deceptive behaviour of terrorists is camouflaged by the dishonest behaviour of much of the general population. Artificial intelligence is a powerful tool and can be extremely useful in today's mass of information, though the results generated by AI techniques are difficult for regular users to interpret without an effective method of visualisation such as DScentTrail.

Appendix A - DScent Data Dictionary

LOCATION_TYPES	The different types of location			
NAME	The name of the location type	Checkpoint Investigation Login Open Shop site	Varchar2(64B)	PK

LOCATIONS	The location details for the LBG (location based game)			
LOCATION	The unique identifier for the location.	-1 0 1 2 3 4 5 6 7 8 9	Number(38,0)	PK
NAME	The name of the location	login room the wilderness investigation room near builders far builders near electricians far electricians red site blue site green site yellow site	Varchar2(128B)	
TYPE	The name of the location type	Open Investigation Shop Site Login	Varchar2(64B)	FK to LOCATION_ TYPES (name)
AREA	Line drawing for area of location		SDO Geometry	
DESCRIPTION	Not used		Varchar2(1024B)	
OWNER	Which team owns the location, i.e. red site belongs to the red team. Only sites have owners.	1 2 3 4	Number	FK to LOG_TEAMS (teamid)
ICON	The web address of picture		Varchar2(512B)	

LOG_ATTEMPT_TASK	An entry is logged in this table when a player attempts to complete a task			
GAMEID	The unique identifier for the game		Number	
TEAMID	The unique identifier for the team	1 to 4	Number	
TASK	The name of the game task	Frame construction Site clearance Set timers Weaken structure Wiring landscaping trip wires set explosion	Varchar2(256B)	
SENT	The timestamp of when the player attempted to complete the task (press the button to complete)		Number	
RECEIVED	The timestamp of when the server received to above message from the player's device.		Number	
SUCCESS	Whether the task was successful or not	0 or 1	Number(38,0)	

LOG_CONNECTIONS	Keeps a record of when a device connects or disconnects to or from game server			
GAMEID	Unique identifier for the game		Number(38,0)	
CONNECTIONID	Unique identifier for the connection between the game device and the server		Number(38,0)	
RECEIVED			Number(38,0)	
IPADDRESS	IP address for the device		Varchar2(4000B)	
PORT	Port for the device		Number	
ACTION	If the device is connected or disconnected to the server or if connection has been lost.	Connect Disconnect Lost	Varchar2(4000B)	

LOG_GAME	Persistent game data.			
GAMEID	Unique identifier for the game		Number	
EVENT	An event during the game	RESET START PAUSE COMPLETE	Varchar2(4000B)	
TIMESTAMP	The time the game was either started, paused, reset or completed		Number	
INSTIGATOR	The winning team of the game	1, 2, 3, 4	Varchar2(4000B)	

LOG_INVESTIGATE	Logs the requests from the investigator to investigate a player			
GAMEID	Unique identifier for the game		Number	
CONNECTIONID	Unique identifier for the game device		Number	
SENT	The time the request was sent to request an investigation		Number	
RECEIVED	The time the request was received to request an investigation		Number	
TARGET	PlayerId of the person being investigated		Number	

LOG_LOCATIONS	Records when a player enters a location There exists multiple LOG_LOCATION tables with the game number appended			
GAMEID	Unique identifier for the game		Number	
CONNECTIONID	Unique identifier for the game device		Number	
SENT	The time the message was sent to the server from the device		Number	
RECEIVED	The time the message was received by the server from the device		Number	
NEWLOCATION	The LOCATIONID of the location just entered		Number	
PLAYER			Number	

LOG_LOGIN	Game login details for each player (core table)			
GAMEID	Unique identifier for a game		Number(38,0)	
CONNECTIONID	Unique identifier for the game device		Number(38,0)	
SENT	The timestamp at which the login attempt was made from the player device.		Number(38,0)	
RECEIVED	The timestamp at which the login attempt was received by the server.		Number(38,0)	
ACTION	Login/logout In the data, for the same CONNECTIONID there should always be a LOGIN followed by a LOGOUT. Though with different CONNECTIONID's a LOGOUT is assumed.	Login Logout	Varchar2(256B)	
PLAYER	Unique identifier for the player	1 to 14	Number(38,0)	
SUCCESS	If the request was successful	0 or 1	Number(38,0)	

LOG_MOVE	Logs movement details There exists multiple LOG_MOVE tables with the game number appended			
GAMEID	Unique identifier for a game		Number(38,0)	
CONNECTIONID	Unique identifier for the game device		Number(38,0)	
SENT	This time should be an exact match to the received time in the LOG_LOCATIONS table.		Number	
RECEIVED			Number	
LONGITUDE	The longitude position of the player device at the time the move message was sent to the server.		Number	
LATITUDE	The latitude position of the player device at the time the move message was sent to the server.		Number	
CONDITION	Filtered = checked to be a valid co-ordinate Illegal = not valid GPS co-ordinate	Filtered Illegal	Varchar2(16B)	
PROVIDER		GPS NETWORK		
ACCURACY			Number	
SPEED			Number	
PLAYER	The Player who has moved		Number	

LOG_OFFER	Subcontract offer details			
GAMEID	Unique identifier for the game		Number	
CONNECTIONID	Unique identifier for the game device		Number	
SENT	The time the device sent the message to the server		Number	
RECEIVED	The time the server received the message from the device		Number	
TARGET	The unique identifier for the player whom has been made an offer		Number	
PLAYER	The player who has made the offer		Number	

LOG_PLAYERS	Log table for player information			
PLAYER	The player id		Number(38,0)	
GAMEID	The unique identifier for the game		Number	
NAME	The name of the player (Initially Red, Blue, Green and Yellow 1,2 and 3)		Varchar2(128B)	
TEAMID	The team id for the player		Number(38,0)	
ROLE	The role of the player		Varchar2(4000B)	
BANK	The starting amount of cash for a player		Number	

LOG_PURCHASE	Game purchase details for a player device			
GAMEID	Unique identifier for a game		Number	
CONNECTIONID	Unique identifier for the game device		Number	
SENT	The time the purchase message was sent to the server from the device		Number	
RECEIVED	The time the purchase message was received by the server		Number	
LOCATION	Unique identifier for the location		Number(38,0)	
ITEM	The name of the resource.	Dynamite Wiring Blocks Soil Fertiliser	Varchar2(256B)	
QUANTITY	The quantity of the resource_type		Number	
SUCCESS	Whether the purchase was successful	0, 1	Number(38,0)	
PLAYER	The player id who has attempted the purchase		Number	

LOG_REGISTRATIONS	The sequence is: connection made, registration, login			
GAMEID			Number(38,0)	
CONNECTIONID			Number(38,0)	
RECEIVED			Number(38,0)	
DEVICEID			Varchar2(256B)	
DEVICEIDTYPE			Varchar2(128B)	

LOG_REVEAL	Van search details for a game.			
GAMEID	Unique identifier for a game		Number	
CONNECTIONID	Unique identifier for the game device		Number	
SENT			Number	
RECEIVED			Number	
ITEM1	The first item/resourcetype displayed to the investigator. Alternatively, this may be "BANK" which indicates that cash was revealed.	Dynamite Wiring Blocks Soil Fertiliser Bank	Varchar2(256B)	
ITEM2	The second item/resourcetype displayed to the investigator. "NONE" is entered if the first item is BANK. "UNKNOWN" is entered if only one item was in the van.	Dynamite Wiring Blocks Soil Fertiliser None Unknown	Varchar2(256B)	
AWARD	The amount of money awarded to the player for the reveal. £50 is awarded for a cash reveal, nothing for revealing items.	50	Number	
PLAYER	The player id who has been asked to reveal 2 items in their van or cash		Number	

LOG_STOCK_ROTATION	A log table for stock delivery details to the local/near shops with rotating stock levels.			
GAMEID	Unique identifier for the game		Number	
AGENTID	Unique identifier for the game device	-1, -2 Minus numbers represent agents, of which there are two, one changing electrical items and the other builders.	Number	
SENT			Number	
RECEIVED			Number	
LOCATION	Unique identifier for the location		Number(38,0)	
RESOURCE	The name of the resource	Dynamite Wiring Blocks Soil Fertiliser	Varchar2(256B)	
QUANTITY	The quantity of the resource delivered		Number	

LOG_SUBCONTRACT	Subcontract details for players			
GAMEID	Unique identifier for a game		Number	
CONNECTIONID	Unique identifier for the game device		Number	
SENT			Number	
RECEIVED			Number	
TEAMID	Unique identifier for a team		Number	
ACTION	Whether the player accepts or rejects a subcontract offer	Reject Accept	Varchar2(256B)	
PLAYER			Number	

LOG_SWAP_VAN	Van swapping details for the player who currently has the van			
GAMEID	Unique identifier for the game		Number	
CONNECTIONID	Unique identifier for the game device		Number	
SENT			Number	
RECEIVED			Number	
TARGET	The unique identifier for the player who is getting the van	1 to 12	Number	
SUCCESS	Whether the van swap was successful	0 or 1	Number	
PLAYER			Number	

LOG_TEAMS	Team details			
TEAMID	The identifier for a team	0 to 4	Number(38,0)	
GAMEID	The unique identifier for the game		Number	
NAME	The name of the team	Red Team Blue Team Yellow Team Green Team Investigators	Varchar2(128B)	
TYPE	The type of the team	BUILDER TERRORIST POLICE	Varchar2(64B)	
VANDRIVER	The player who was initially assigned the van at the start of the game		Number(38,0)	

LOG_TRANSFER	Cash transfer details for the player who is sending the transfer			
GAMEID	Unique identifier for the game		Number	
CONNECTIONID	Unique identifier for the game device		Number	
SENT			Number	
RECEIVED			Number	
TARGET	The unique identifier for the player who is receiving the cash transfer	1 to 12	Number	
QUANTITY	The amount of cash being transferred		Number	
SUCCESS	Whether the transfer was a success or not	0 or 1	Number(38,0)	
PLAYER	The player id of the player who is transferring cash to a target player		Number	

LOG_UNLOAD	Unloading details			
GAMEID	Unique identifier for the game		Number	
CONNECTIONID	Unique identifier for the game device		Number	
SENT			Number	
RECEIVED			Number	
LOCATION	Unique identifier for the 4 different sites	6,7,8 and 9	Number(38,0)	
RESOURCE	The resource which was unloaded	Dynamite Wiring Blocks Soil Fertiliser	Varchar2 (256B)	
QUANTITY	The quantity of the resource which was unloaded		Number	
SUCCESS	Whether the unload was successful or not	0 or 1	Number(38,0)	
PLAYER			Number	

LOG_WEIGHING	Weight details for van. (James will try and include a weight)			
GAMEID	Unique identifier for the game		Number	
CONNECTIONID	Unique identifier for the game device		Number	
TIMESTAMP			Number	
SUCCESS	Whether the weight check was successful		Number	
AWARD	The cash award received for the weight check	A pos or neg number	Number	
WEIGHT	The weight of the van at a van weigh check		Number	
SOURCE	This is currently set to either CHECKPOINT or INVESTIGATOR		Varchar2(256B)	
PLAYER	The player id of the player who is being weighed		Number	

PLAYERS	Player details			
PLAYER	Unique identifier for the player	1 to 14	Number(38,0)	PK
NAME	The games name for the player	Red 1 Red 2 Red 3 Blue 1 Blue 2 Blue 3 Green 1 Green 2 Green 3 Yellow 1 Yellow 2 Yellow 3 Quincy Columbo	Varchar2(128B)	
PASSWORD	The password for the game device		Varchar2(64B)	
TEAMID	The unique identifier for the team to which the player belongs	0 to 4	Number(38,0)	FK to TEAMS (teamId)
ROLE	The role of the player	Builder Electrician Foreman Explosives	Varchar2(4000B)	FK to ROLES (name)
LOCATION	The current location of the player		Number(38,0)	FK to LOCATIONS
LASTCHECKPOINT	The unique identifier for the location of the last visited checkpoint		Number(38,0)	
LASTCHECKED	The time of the above checkpoint		Number(38,0)	
BANK	The current amount of cash a player has		number	
CONTRACTEDTO	The team id of the team they are currently contracted to ** may change		Number	
ICON	Web address of where picture is stored		Varchar2(512B)	

PROGRESS				
TEAMID			Number(38,0)	PK FK to TEAMS
LASTUPDATED			Number(38,0)	
TASKNAME			Varchar2(64B)	PK FK to TASKS
STATUS			Varchar2(64B)	FK to PROGRESS_STATUSES

PROGRESS_STATUSES				
NAME		Complete Incomplete Ready	Varchar2(64)	PK

TEAMS				
	Team details - holds only information for the last game played			
TEAMID	Unique identifier for a team	0 to 4	Number(38,0)	PK
NAME	The name of the team	Red Team Blue Team Green Team Yellow Team Investigators	Varchar2(128B)	
TYPE	The type of the team	Builder Terrorist Police Admin	Varchar2(64B)	FK to TEAM_TYPES
VANDRIVER	PlayerId of the van driver for the team		Number(38,0)	FK to PLAYERS

RESOURCES				
NAME		Wiring Dynamite Blocks Soil Fertiliser Money	Varchar2(64B)	PK
COST		100 400 200 300 100 1	Number	
WEIGHT		200 200 1000 500 250 0	Number	

REVEALS				
PLAYER	Unique identifier for the player		Number(38,0)	PK
RESOURCE TYPE	The name of the item revealed.	Dynamite Wiring Blocks Soil Fertiliser	Varchar2(64B)	PK
QUANTITY	Quantity of the item revealed	1 or 2	Varchar2(4000B)	
LASTUPDATED	Timestamp		Number(38,0)	

ROLES				
NAME	Lookup table for roles	Admin Investigator Foreman Builder Electrician Explosives	Varchar2(64B)	PK
CONTRACTABLE	If the role is contractible – true or false	0 or 1	Number(1,0)	

SHOPS	Shop information			
LOCATION	Unique identifier for the shop location	2 3 4 5	Number(38,0)	PK FK to LOCATIONS
TYPE	The name of the shop	Near_builders Far_builders Near_electricians Far_electricians	Varchar2(64B)	
PROXIMITY	Whether it is near or far	Near Far	Varchar2(64B)	

SITES	Site information			
LOCATION	Unique identifier for the site		Number(38,0)	PK FK to LOCATIONS
TEAMID	Unique identifier for the team owning the site		Number(38,0)	FK to LOG_TEAMS

STOCK	Current view of what shops and 4 sites have at any point in time (we probably will not need this)			
LOCATION	Unique identifier for the shop or site	2 – 9	Number(38,0)	PK FK to LOCATIONS
NAME	Name of the resource item	Dynamite Wiring Blocks Soil Fertiliser	Varchar2(64B)	PK
QUANTITY	Quantity of the resource item		Number(38,0)	

TASKS	Lookup table for tasks			
NAME	Task name	Site_clearance Frame_construction Wiring Landscaping Set_timers Weaken_structure Trip_wires Set_explosion	Varchar2(64B)	PK
TASKLEVEL	The grouping of the task. This is no longer used as the rule of not starting tasks 3 or 4 until tasks 1 and 2 are complete has been removed	1 2	Number(38,0)	
TEAMTYPE	The type of team	Builder Terrorist Admin Police	Varchar2(64B)	

TEAM_TYPES	Lookup table for team types			
NAME		Admin Builder Police Terrorist	Varchar2(64B)	PK

VAN_CARGO				
TEAMID			Number(38,0)	PK FK to TEAMS
QUANTITY			Number(38,0)	
NAME	The resource name		Varchar2(64B)	PK FK to RESOURCES

Appendix C - Results Cross Reference

Experiment	Neural Engine	Architecture	# of Hidden Neurons	Presentation of Patterns	Game Number	Colour	Locations	Stock Items	Van Weight	Empty Columns	Stock Take	Separate Round Patterns	# of Columns	# of Epochs	RMSE	Test Results (Overall, Terrorists)	% of Terrorists Correctly Identified	Input Files	Comments
A	E	Standard	13	Auto	N	N	Y	Y	Y	N	Y	N			<0.01	20/40 6/15		Train with First 116, test with last 28	
B	E	Standard	13	Balanced	N	N	Y	Y	Y	N	Y	N			<0.01	22/40 8/15		Train with First 116, test with last 28	
C	E	Standard	13	Random	N	N	Y	Y	Y	N	Y	N			<0.01	20/40 7/15		Train with First 116, test with last 28	
D	J	I/P, Hidden & O/P layers = Sigmoid MLP, Back Prop. Learning Rate = 0.7, Momentum = 0.6	10	Online/Random	Y	Y	Y	Y	Y	Y	Y	N	123	400	0.01	19/28 3/7	68% 43%	Train with last 116, test with first 28	
D1	J	As above	13 11%	Online/Random	Y	Y	Y	Y	Y	Y	Y	N	123	400	0.01	21/28 4/7	75% 57%	Train with last 116, test with first 28	
D2	J	As above	13	Online/Random	Y	Y	Y	Y	Y	Y	Y	N	123	220	0.04	16/28 2/7	57% 29%	Train with last 116, test with first 28	Now with less epochs
D3	J	As above	13	Online/Random	Y	Y	Y	Y	Y	Y	Y	N	123	240	0.07	19/28 4/7	68% 57%	Train with last 116, test with first 28	Now with a few more epochs
D4	J	As above	15	Online/Random	Y	Y	Y	Y	Y	Y	Y	N	123	400	0.01	19/28 4/7	68% 57%	Train with last 116, test with first 28	
D5	J	As above	13	Online/Random	Y	Y	Y	Y	Y	Y	Y	N	123	400	0.07	18/28 8/15	64% 53%	Train with First 116, test with last 28	
D6	J	As above	13	Online/Random	Y	Y	Y	Y	Y	Y	Y	N	123	220	0.07	21/28 9/15	75% 60%	Train with First 116, test with last 28	Now with less epochs
D7	J	As above	13	Online/Random	Y	Y	Y	Y	Y	Y	Y	N	123	400	0.01	12/28 6/20	43% 30%	Least possible amount of terrorist patterns in training file and most in test.	
D8	J	As above	13	Online/Random	Y	Y	Y	Y	Y	Y	Y	N	123	220	0.02	19/28 12/20	68% 60%	Least possible amount of terrorist patterns in training file and most in test.	Now with less epochs
D9	J	As above	17	Online/Random	Y	Y	Y	Y	Y	Y	Y	N	123	400	0.01	17/28 0/7	61% 0%	Train with last 116, test with first 28	
D10	J	As above	40	Online/Random	Y	Y	Y	Y	Y	Y	Y	N	123	300	0.01	18/28 2/7	64% 29%	Train with last 116, test with first 28	
D11	J	As above	40	Online/Random	Y	Y	Y	Y	Y	Y	Y	N	123	210	0.07	18/28 7/15	64% 47%	Train with First 116, test with last 28	
D12	J	As above	65	Online/Random	Y	Y	Y	Y	Y	Y	Y	N	123	300	0.01	18/28 1/7	64% 14%	Train with last 116, test with first 28	
D13	J	As above	65	Online/Random	Y	Y	Y	Y	Y	Y	Y	N	123	300	0.07	18/28 7/15	64% 47%	Train with First 116, test with last 28	

D14	J	As above	65	Online/ Random	Y	Y	Y	Y	Y	Y	Y	Y	N	123	300	0.01	15/28 8/20	54% 40%	Least possible amount of terrorist patterns in training file and most in test.	
D15	J	As above	80	Online/ Random	Y	Y	Y	Y	Y	Y	Y	Y	N	123	300	0.07	19/28 2/7	68% 29%	Train with last 116, test with first 28	
D16	J	As above	80	Online/ Random	Y	Y	Y	Y	Y	Y	Y	Y	N	123	300	0.07	19/28 8/15	68% 53%	Train with First 116, test with last 28	
D17	J	As above	80	Online/ Random	Y	Y	Y	Y	Y	Y	Y	Y	N	123	180	0.08	18/28 7/15	64% 47%	Train with First 116, test with last 28	Now with less epochs
D18	J	As above	80	Online/ Random	Y	Y	Y	Y	Y	Y	Y	Y	N	123	300	0.01	15/28 8/20	54% 40%	Least possible amount of terrorist patterns in training file and most in test.	
D19	J	As above	100	Online/ Random	Y	Y	Y	Y	Y	Y	Y	Y	N	123	200	0.07	17/28 0/7	61% 0%	Train with last 116, test with first 28	
D20	J	As above	100	Online/ Random	Y	Y	Y	Y	Y	Y	Y	Y	N	123	200	0.07	17/28 8/15	61% 53%	Train with First 116, test with last 28	
D21	J	As above	100	Online/ Random	Y	Y	Y	Y	Y	Y	Y	Y	N	123	200	0.02	14/28 7/20	50% 35%	Least possible amount of terrorist patterns in training file and most in test.	
E	J	As above	11	Online/ Random	Y	Y	Y	Y	Y	N	Y	N	N	101	300	0.01	16/28 1/7	57% 14%	Train with last 116, test with first 28	
E1	J	As above	11	Online/ Random	Y	Y	Y	Y	Y	N	Y	N	N	101	200	0.03	17/28 3/7	61% 43%	Train with last 116, test with first 28	
E2	J	As above	11	Online/ Random	Y	Y	Y	Y	Y	N	Y	N	N	101	150	0.09	20/28 3/7	71% 43%	Train with last 116, test with first 28	
E3	J	As above	11	Online/ Random	Y	Y	Y	Y	Y	N	Y	N	N	101	300	0.07	18/28 6/15	64% 40%	Train with First 116, test with last 28	
E4	J	As above	11	Online/ Random	Y	Y	Y	Y	Y	N	Y	N	N	101	200	0.07	18/28 7/15	64% 47%	Train with First 116, test with last 28	Now with less epochs
E5	J	As above	11	Online/ Random	Y	Y	Y	Y	Y	N	Y	N	N	101	300	0.01	14/28 7/20	50% 35%	Least possible amount of terrorist patterns in training file and most in test.	
E6	J	As above	11	Online/ Random	Y	Y	Y	Y	Y	N	Y	N	N	101	180	0.12	12/28 6/20	43% 30%	Least possible amount of terrorist patterns in training file and most in test.	Reduced the epochs.
E7	J	As above	65	Online/ Random	Y	Y	Y	Y	Y	N	Y	N	N	101	300	0.01	14/28 9/20	50% 45%	Least possible amount of terrorist patterns in training file and most in test.	
E8	J	As above	65	Online/ Random	Y	Y	Y	Y	Y	N	Y	N	N	101	180	0.02	14/28 8/20	50% 40%	Least possible amount of terrorist patterns in training file and most in test.	Reduced the epochs.
F	J	As above	11	Online/ Random	Y	N	Y	Y	Y	N	Y	N	N	100	300	0.01	15/28 1/7	54% 14%	Train with last 116, test with first 28	
F1	J	As above	11	Online/ Random	Y	N	Y	Y	Y	N	Y	N	N	100	300	0.09	17/28 8/15	61% 53%	Train with First 116, test with last 28	
F2	J	As above	11	Online/ Random	Y	N	Y	Y	Y	N	Y	N	N	100	300	0.01	14/28 7/20	50% 43%	Least possible amount of terrorist patterns in training file and most in test.	
G	J	As above	11	Online/ Random	N	N	Y	Y	Y	N	Y	N	N	99	300	0.01	18/28 3/7	64% 43%	Train with last 116, test with first 28	
G1	J	As above	8 8%	Online/ Random	N	N	Y	Y	Y	N	Y	N	N	99	300	0.13	19/28 3/7	68% 43%	Train with last 116, test with first 28	With less neurons

G2	J	As above	11	Online/ Random	N	N	Y	Y	Y	N	Y	N	99	300	0.09	20/28 9/15	71% 60%	Train with First 116, test with last 28	
G3	J	As above	8	Online/ Random	N	N	Y	Y	Y	N	Y	N	99	300	0.09	21/28 9/15	75% 60%	Train with First 116, test with last 28	With less neurons
G4	J	As above	11	Online/ Random	N	N	Y	Y	Y	N	Y	N	99	300	0.01	11/28 6/20	39% 30%	Least possible amount of terrorist patterns in training file and most in test.	
G5	J	As above	8	Online/ Random	N	N	Y	Y	Y	N	Y	N	99	300	0.07	18/28 12/20	64% 60%	Least possible amount of terrorist patterns in training file and most in test.	Less Neurons. Number correct is averaging 69% over the 3 files & number of correct terrorists is averaging 54%.
H	J	As above	7	Online/ Random	N	N	Y	Y	Y	N	N	N	64	5000	0.27	16/28 4/7	57% 57%	Train with last 116, test with first 28	
H1	J	As above	42	Online/ Random	N	N	Y	Y	Y	N	N	N	64	300	0.19	12/28 5/7	43% 71%	Train with last 116, test with first 28	With more neurons. This is only 71% as it is identifying many patterns as '1'.
H2	J	As above	7	Online/ Random	N	N	Y	Y	Y	N	N	N	64	5000	0.24	18/28 11/15	64% 73%	Train with First 116, test with last 28	
H3	J	As above	7	Online/ Random	N	N	Y	Y	Y	N	N	N	64	5000	0.1	9/28 4/20	32% 20%	Least possible amount of terrorist patterns in training file and most in test.	
I	J	As above	10 11%	Online/ Random	N	N	Y	Y	N	N	Y	N	92	1500	0.32	18/28 5/7	64% 71%	Train with last 116, test with first 28	
I1	J	As above	10	Online/ Random	N	N	Y	Y	N	N	Y	N	92	1500	0.27	19/28 12/15	68% 80%	Train with First 116, test with last 28	
I2	J	As above	10	Online/ Random	N	N	Y	Y	N	N	Y	N	92	1500	0.25	10/28 3/20	36% 15%	Least possible amount of terrorist patterns in training file and most in test.	Was doing well until here.
J	J	As above	7	Online/ Random	N	N	Y	N	Y	N	Y	N	66	400	0.07	13/28 1/7	46% 14%	Train with last 116, test with first 28	
J1	J	As above	7	Online/ Random	N	N	Y	N	Y	N	Y	N	66	400	0.05	15/28 5/15	54% 33%	Train with First 116, test with last 28	
J2	J	As above	7	Online/ Random	N	N	Y	N	Y	N	Y	N	66	400	0.11	16/28 11/20	57% 55%	Least possible amount of terrorist patterns in training file and most in test.	
K	J	As above	2	Online/ Random	Y	Y	Y	Y	Y	N	Y	Y	18	1000	0.33	/	/	Train with last 688, test with first 236	All training results were '0' didn't bother with test.
L	J	As above	80	Batch/In Sequence	Y	Y	Y	Y	Y	Y	Y	N	123	400	0.54	/	/	Train with last 116, test with first 28	Learning Mode=1, presented all the 116 train pats in batch mode. Worked/ didn't when set up identically.

Appendix D - Test Results

Desire												Desired							Desired					
	D	D1	D2	D3	D4	D9	D10	D12	D15	D19	D5	D6	D11	D13	D16	D17	D20	D7	D8	D14	D18	D21		
0	0	0.3	0	0	0.1	0	0	0	0	0	1	1	0.8	1	0.4	1	0.6	0.9	1	0.5	0.6	0.9	0.9	0.8
0	0.2	0.5	0.9	0	0.3	0.2	0.3	1	0	0	1	1	0.9	1	1	1	1	1	0	0	0	0	0	0
1	0.9	0.8	0.6	1	1	0	0	0.9	0.9	0.1	0	0.8	0.6	0.9	0.6	0.7	0.6	0.6	0	0.1	0	0	0.2	0
0	0.2	0.1	0.1	0.1	0.1	0.2	0.3	0.3	0	0.2	1	1	0.7	1	1	0.9	0.8	0.9	1	0	0	0	0	0
0	0	0.5	0.1	0	0.1	0	0	0	0	0	0	0	0	0	0	0	0.1	1	0	0	0	0	0	0
0	0	0	0.8	0	0	0	0	0	0	0	0	0	0	0	0	0	0	1	0.9	0.9	0.8	0.6	0.4	0
0	1	1	1	0.9	1	0.9	1	1	1	1	1	0	0	0	0	0	0	0	0	0	0.1	0.2	0.1	0
1	0.8	0.6	1	0.7	0.8	0.5	0.9	0.4	0.7	0.2	0	0.2	0	0.1	0	0.1	0	0.5	1	0	0	0	0	0
0	0.8	0.4	0.9	0.9	0.9	0.8	1	0.8	1	0.9	1	1	0.9	1	0.9	1	0.9	1	0	0	0	0	0	0
0	1	1	1	0.8	1	0.6	1	0.5	0.9	1	1	0.9	0.9	0.3	0.9	0.1	0.9	0.2	1	0	0	0	0	0
1	0	0	0	0	0	0	0	0	0	0	0	0	0.2	0	0	0	0	0	1	0	0.2	0	0	0
0	0.3	0	0.2	0.7	0.9	0	0.9	0	0.1	0.1	1	1	0.8	0.9	0.8	1	0.5	0.8	1	0.3	0.6	0.1	0.2	0.2
0	0	0	0	0	0.1	0	0	0	0	0	1	0.5	0	0	0	0.1	0	0	1	0.8	0.7	0.6	0.8	0.8
1	0.1	0.5	0.1	1	0.8	0.2	0.9	0.1	0.5	0.4	0	0.1	0.1	0	0	0	0	0	1	0.3	0.9	0.8	0.4	0.7
0	0	0	0	0	0	0	0	0	0	0	0	0	0	0.1	0	0.1	0.1	0	1	0	0	0	0	0
0	0	0	0	0	0	0	0	0	0	0	1	1	0.8	1	1	1	1	1	0	0	0.3	0	0	0
0	0	0	0	0	0	0	0	0	0	0	0	0.5	0	0	0.3	0	0	0	1	0	1	0.3	0	0.3
0	0	0	0	0	0	0	0	0	0	0	1	1	0.8	1	1	1	1	1	1	1	1	1	1	1
1	0	0	0	0	0	0	0	0	0	0	1	0	0	0.1	0.1	0	0	0	0	1	1	1	1	1
0	0	0	0	0	0	0	0	0	0	0	1	0	0	0	0	0	0	0	1	1	1	1	1	1
1	0.6	0.9	0	0.8	0.8	0	0	0	0	0	0	0	0	0	0	0	0	0	1	0.1	1	0.3	0.7	0.2
0	1	1	1	0.7	1	1	0.9	1	0.9	1	1	0	0	0.1	0.1	0	0	0	1	0	0.4	0	0.1	0
0	0.6	0.4	1	0	0.8	0	0	0	0	0	0	0	0	0	0	0.2	0	0	0	0	0	0	0	0
0	0	0.1	0.2	0	0	0	0	0	0	0	1	0	0	0	0	0	0	0	1	0.9	1	0.9	0.8	0.5
0	0	0	0	0	0	0	0	0	0	0	1	0.4	0.8	0.4	0.3	0.5	0.2	0.6	0	0.5	0	0	0	0.3
0	0	0.1	0.3	0.2	0.4	0.1	0.1	0.2	0.2	0	0	1	0.4	1	0.9	0.9	0.7	0.9	1	1	0.7	1	1	1
0	0	0	0	0	0	0	0	0	0	0	0	0	0	0.1	0	0	0	0	1	0	0.8	0.1	0	0
1	0.2	0.1	0	0.2	0.1	0	0	0.3	0.1	0	0	0	0	0	0	0	0	0	1	0	0	0	0	0
Total	19	21	16	20	19	17	18	18	19	17	18	21	18	18	19	18	17	12	19	15	15	14	14	
Terror	3	4	2	4	4	0	2	1	2	0	8	9	7	7	8	7	8	6	12	8	8	7	7	

Desired	E	E1	E2	Desired	E3	E4	Desired	E5	E6	E7	E8	Desired	F	Desired	F1	Desired	F2	Desired	G	G1	Desired	G2	G3	Desired	G4	G5	Desired	H	H1	Desired	H2	Desired	H3	
0	0	0.2	0.5	1	0.7	0.8	1	1	0	0.7	1	0	0	1	0.9	1	1	0	0	0	1	0.1	0.4	1	0.7	0.9	0	0.4	0.6	1	1	1	0	
0	0.8	1	0.1	1	1	0.2	0	0	0.1	0	0	0	0.5	1	1	0	0	0	0.7	0	1	1	0.9	0	0	0	0	0.1	0.4	1	1	0	0	
1	0.4	1	0.9	0	0.1	0.8	0	0.1	0	0	0.3	1	0	0	0.9	0	0.1	1	1	0.9	0	0.1	0.4	0	0.8	0.7	1	1	1	0	0.9	0	0.1	
0	0.1	0.1	0.5	1	0.2	1	1	0.1	0.3	0	0	0	0	1	1	1	0	0	0	0.1	1	1	0.9	1	0	0	0	0.1	0.2	1	0.9	1	1	
0	0.2	0.2	0	0	0	0	1	0	0.1	0	0	0	0.3	0	0	1	0	0	0.1	0	0	0	0	1	0	0.9	0	0.2	1	0	0	1	0	
0	0	0	0	0	0	0	1	0.1	0.9	0.7	0.9	0	0	0	0	1	0	0	0	0	0	0	0	1	0.9	1	0	0.9	1	0	0.9	1	0	
0	1	0.9	1	1	0	0	0	0.1	0.5	0.1	0	0	1	1	0	0	0.4	0	1	0.8	1	0	0	0	0	0.4	0	0.9	0.6	1	0	0	0	
1	0.9	0.3	1	0	0	0	1	0	0	0	0	1	1	0	0.1	1	0	1	0.8	0	0	0	0	1	0	0	1	1	1	0	0.8	1	0	
0	1	0.9	1	1	1	1	0	0	0	0	0	0	1	1	1	0	0	0	0.8	0.7	1	1	1	0	0	0	0	0.9	0.9	1	0	0	0	
0	0.1	1	1	1	0	0.9	1	0	0	0	0	0	1	1	1	1	0	0	1	0.9	1	0.9	1	1	0	0	0	0.9	1	1	0.9	1	0	
1	0	0.6	0	0	0.1	0.1	1	0.9	0	0	0	1	0	0	0	1	0	1	0.7	0	0	0	0	1	0	0.8	1	0.1	0	0	0	1	0	
0	0.1	0.8	0.1	1	1	0.8	1	0	0	0	0.1	0	0.7	1	1	1	0	0	0.2	0.1	1	0.7	1	1	0	0.9	0	0.8	1	1	0.9	1	0.2	
0	0	0	0.1	1	0	0	1	0.1	1	0.6	0.3	0	0	1	0	1	0.4	0	0	0.1	1	0	0	1	0	1	0	0.4	0.7	1	0.1	1	0	
1	0	0.1	1	0	0.1	0	1	0.1	0.1	0.5	0.7	1	0	0	0	1	0.5	1	0	0.9	0	0	0.1	1	0.6	0.4	1	0.1	1	0	0.9	1	0	
0	0	0	0	0	0	0	1	0	0	0	0	0	0	0	0	1	0	0	0	0	0	0	0	1	0	0	0	0.1	0.1	0	1	1	0	
0	0	0	0	1	1	1	0	0	0.1	0	0	0	0	1	0.3	0	0	0	0	0	1	1	1	0	0.9	0	0	0.1	0	1	1	0	0.3	
0	0	0	0	0	0	0.1	1	0	1	1	0.1	0	0	0	0.7	1	0.7	0	0	0	0	0.9	0.5	1	0	0.1	0	0.1	0	0	1	1	0.9	
0	0	0	0	1	0.9	1	1	1	1	1	1	0	0	1	1	1	1	0	0	0	1	1	1	1	1	1	0	1	0.9	1	0.9	1	0.2	
1	0	0.2	0	1	0	0.1	0	1	0.9	1	1	1	0	1	0	0	1	1	0	0	1	0	0	0	1	1	1	1	0.1	1	1	0.2	0	0.6
0	0	0.1	0	1	0	0.1	1	1	1	1	1	0	0	1	0	1	1	0	0	0	1	0	0	1	1	1	0	0.1	0.4	1	0.7	1	0	
1	0.4	0.9	0.5	0	0	0	1	1	0.9	0.8	0.8	1	0	0	0	1	0.3	1	0.4	0.6	0	0	0	1	0.2	1	1	0.9	1	0	0	1	0.3	
0	1	1	1	1	0.2	0.1	1	0	0	0	0	0	1	1	0	1	0	0	1	1	1	0.6	0	1	0.4	0.8	0	1	1	1	0.9	1	0	
0	0.8	1	0.5	0	0.1	0	0	0	0	0	0	0	1	0	0	0	0	0	0.9	1	0	0	0.4	0	0	0	0	0.8	1	0	0.1	0	0	
0	0	0	0	1	0	0	1	0.9	0.3	0.7	0.9	0	0	1	0	1	0.4	0	0.1	0	1	0	0.8	1	0.9	0.9	0	0.1	0.6	1	0.9	1	0	
0	0	0.1	0	1	0.2	0.1	0	0.4	0.8	0.6	0.8	0	0	1	1	0	0.1	0	0	0	1	0.8	0.6	0	0.9	0.1	0	0.1	0.1	1	0.9	0	0.9	
0	0.1	0.4	0	0	0.6	0.9	1	0.3	0.2	1	0.7	0	0	0	1	1	1	0	0.1	0	0	0.9	0.6	1	0.7	1	0	0.1	0.8	0	0	1	1	
0	0.3	0	0	0	0	0	1	0	0	0.4	0.2	0	0	0	0.1	1	1	0	0	0.2	0	0	0	1	0	0	0	1	0.9	0	0	1	0.7	
1	0.5	0.2	0.1	0	0	0	1	0.5	0	0	0	1	0	0	0	1	0	1	0	0.1	0	0	0	1	0	0	1	0.9	0.2	0	0	1	0	
	16	17	20		18	18		14	12	14	14		15		17		14		18	19		20	21		11	18		16	12		18		9	
	1	3	3		6	7		7	6	9	8		1		8		7		3	3		9	9		6	12		4	5		11		4	

Desired	I	Desired		Desired		Desired	J	Desired		Desired	
		I1	I2	I2	J1			J2			
0	0.9	1	1	1	0	0	0	1	1	1	1
0	0.9	1	1	0	0	0	0.8	1	1	0	0
1	0.8	0	1	0	0	1	0.1	0	0	0	0.9
0	0.9	1	1	1	0	0	0	1	1	1	0
0	0.9	0	0.8	1	0	0	0	0	0.4	1	0
0	0.1	0	0	1	0.1	0	0	0	0.1	1	1
0	0.3	1	0.1	0	0	0	1	1	0.4	0	0.8
1	0.6	0	0.1	1	0	1	1	0	0	1	0
0	0.1	1	1	0	0	0	0.4	1	0	0	0
0	0.8	1	1	1	0	0	1	1	1	1	0
1	0.8	0	0.1	1	0	1	0	0	0	1	1
0	0.9	1	1	1	0	0	0	1	0	1	1
0	0.4	1	0	1	0	0	0	1	0.2	1	0.2
1	0.5	0	0	1	0	1	0	0	0	1	0.3
0	0	0	0	1	0	0	0	0	0.7	1	0
0	0	1	0	0	0	0	0.9	1	0	0	0
0	0	0	1	1	0.7	0	0.1	0	0.8	1	0.8
0	0.9	1	1	1	0.4	0	0	1	0.8	1	1
1	0.6	1	1	0	0.2	1	0	1	0	0	1
0	0.3	1	1	1	0.2	0	0.9	1	0	1	1
1	0.9	0	0.1	1	0	1	0.2	0	0.1	1	0.6
0	0.9	1	0.9	1	0	0	1	1	0.2	1	1
0	0.1	0	0.9	0	0	0	1	0	0.1	0	0
0	0	1	0.9	1	0	0	0	1	0	1	1
0	0.2	1	0.8	0	0	0	1	1	0	0	0
0	0.3	0	0.1	1	1	0	1	0	0.9	1	1
0	0.3	0	0.9	1	0.6	0	0	0	0	1	0
1	0	0	1	1	0.3	1	0	0	0	1	0
	18		19		10		13		15		16
	5		12		3		1		5		11

Appendix E - The Root Mean Square Error (RMSE) During Training



Test D

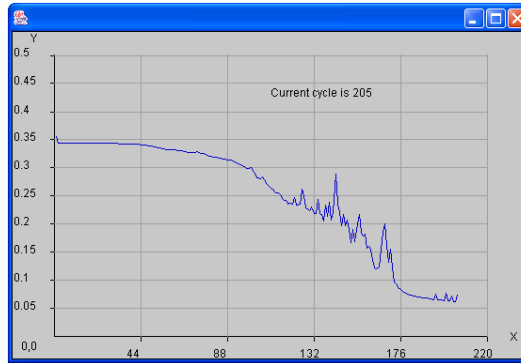

Test D2



Test D4

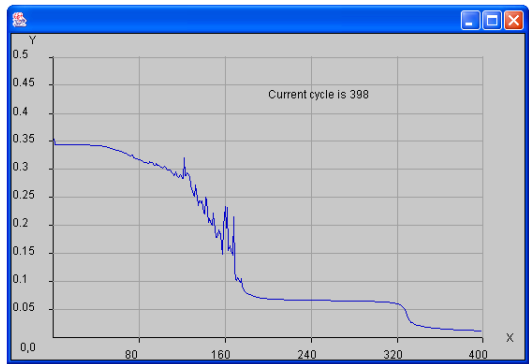

Test D1

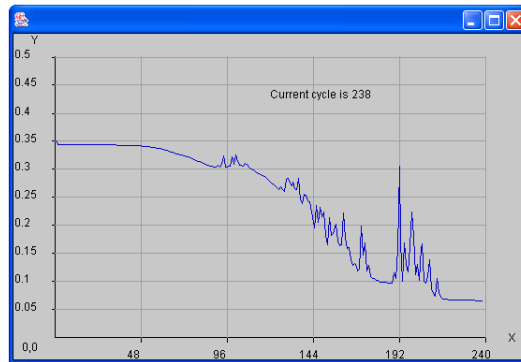

Test D3

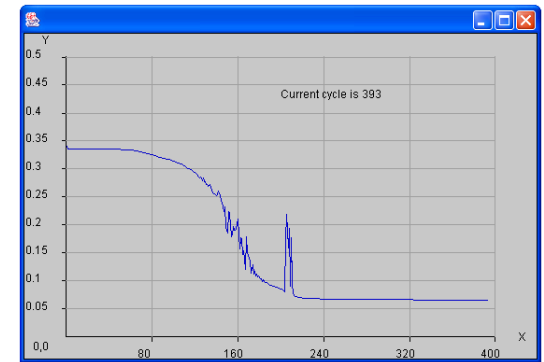

Test D5



Test D6

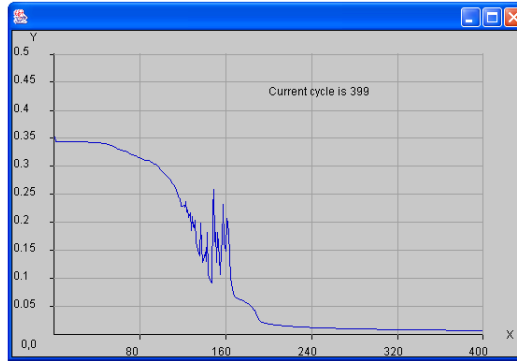

Test D9



Test D12



Test D7

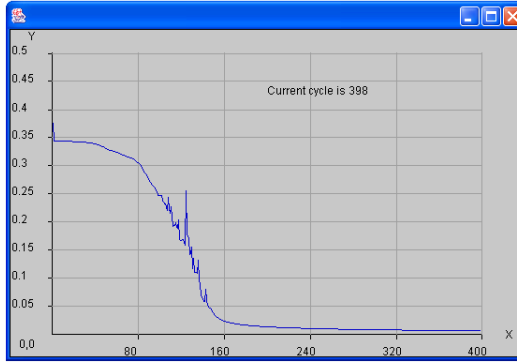

Test D10

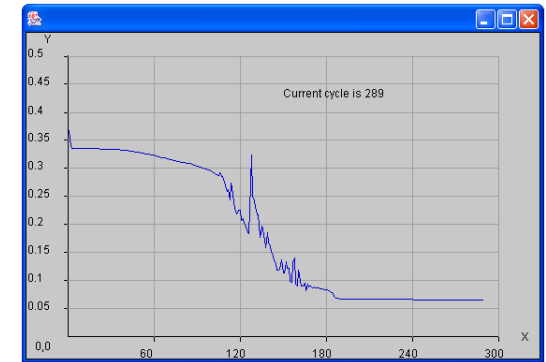

Test D13



Test D8

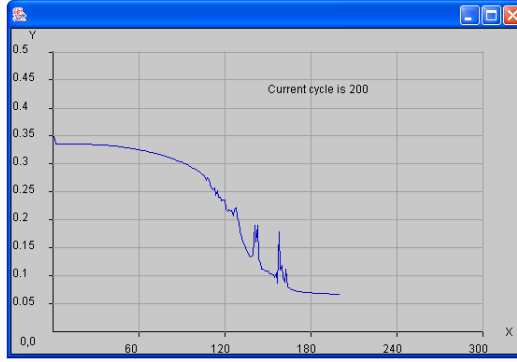

Test D11

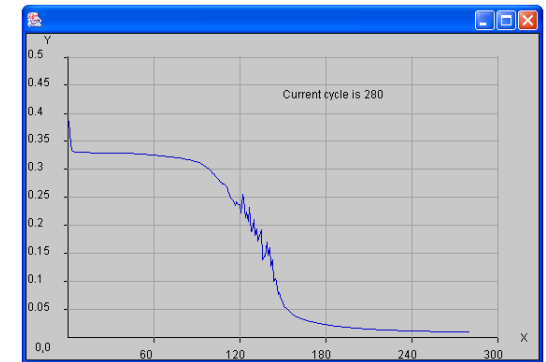

Test D14

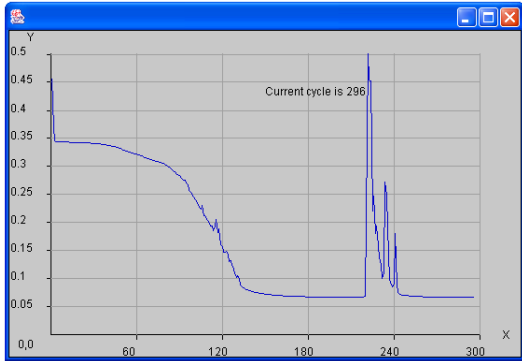

Test D15

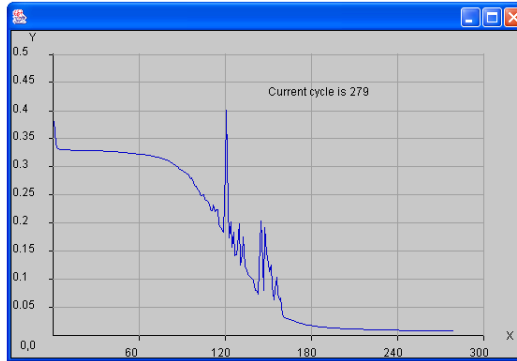

Test D18

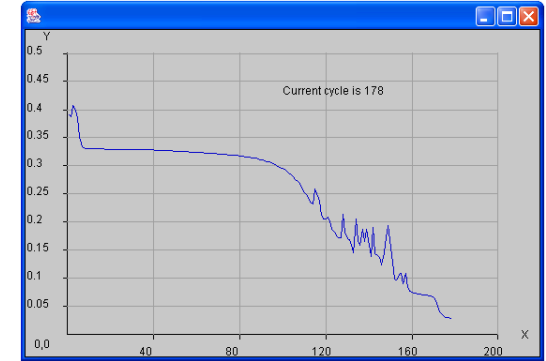

Test D21



Test D16

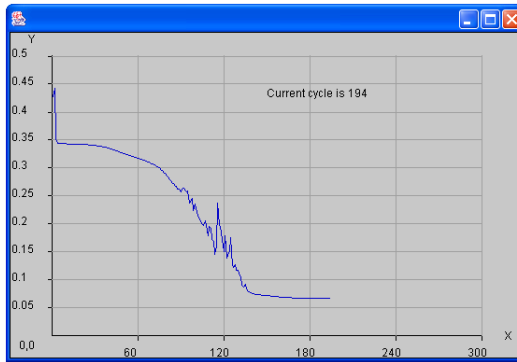

Test D19

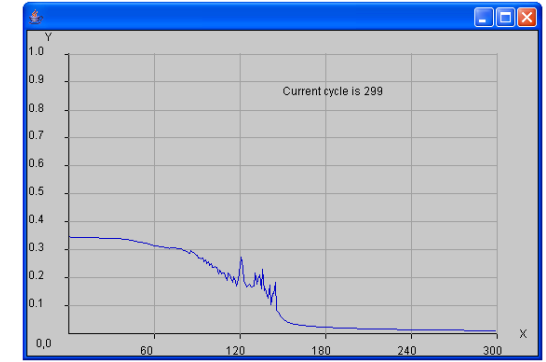

Test E

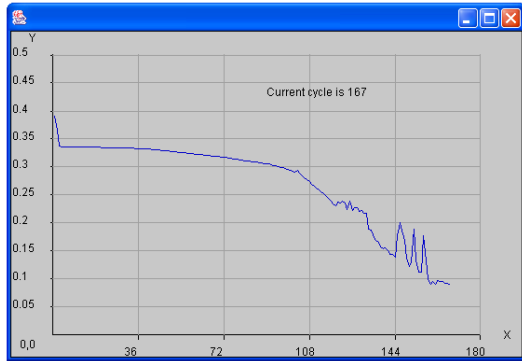

Test D17



Test D20

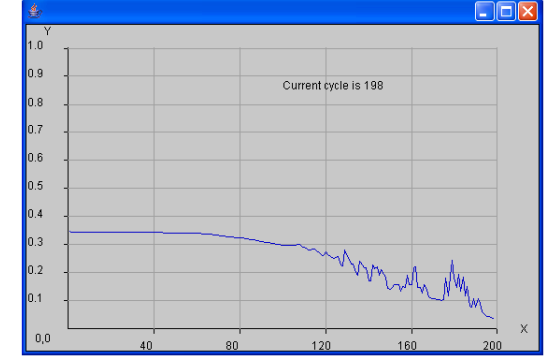

Test E1



Test E2

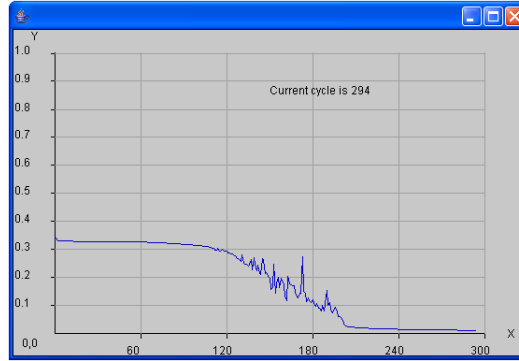

Test E5

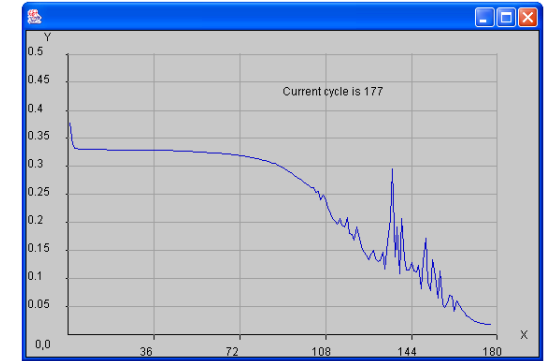

Test E8



Test E3

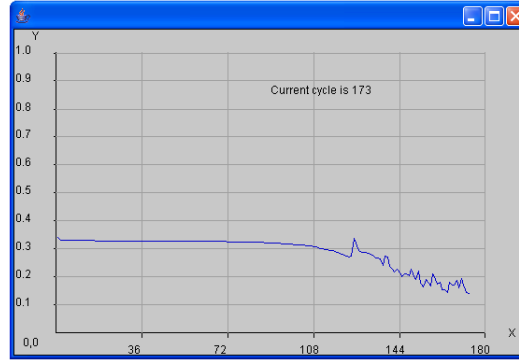

Test E6



Test F



Test E4



Test E7



Test F1



Test F2

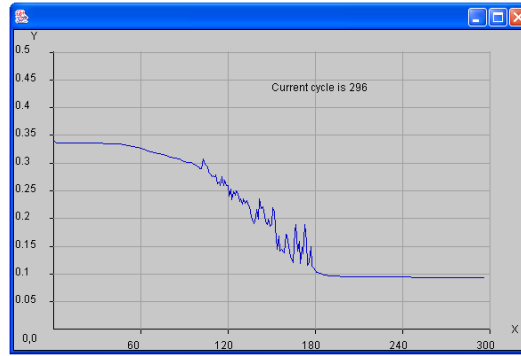

Test G2



Test G5

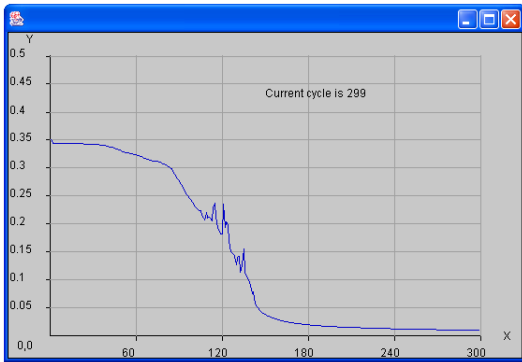

Test G

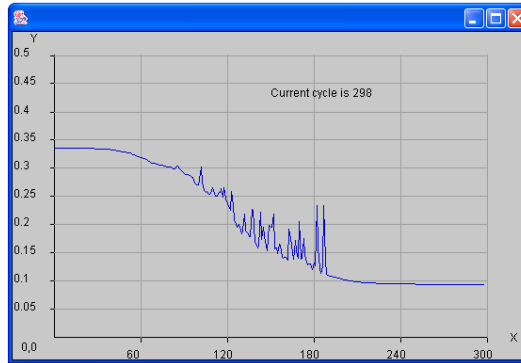

Test G3

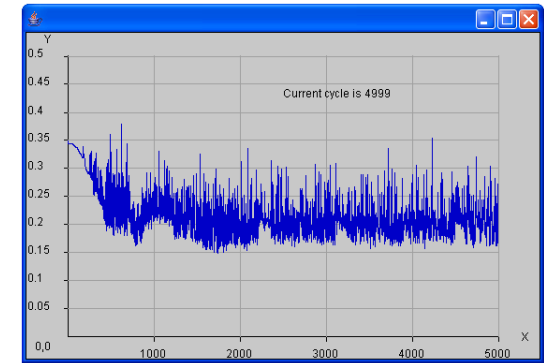

Test H



Test G1

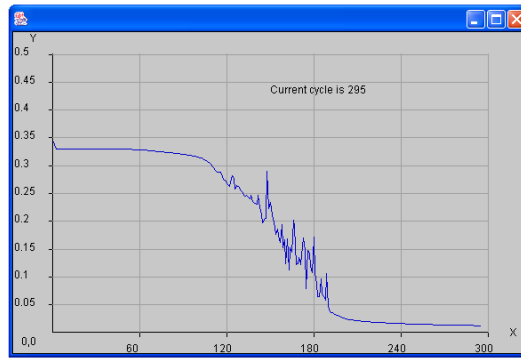

Test G4



Test H1

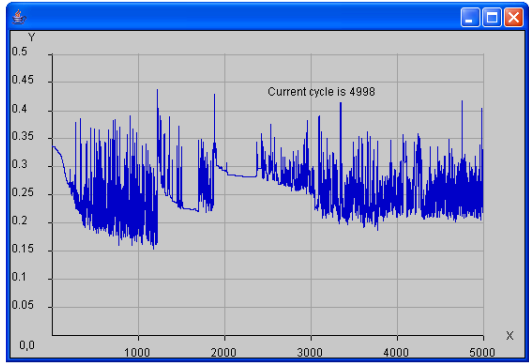

Test H2

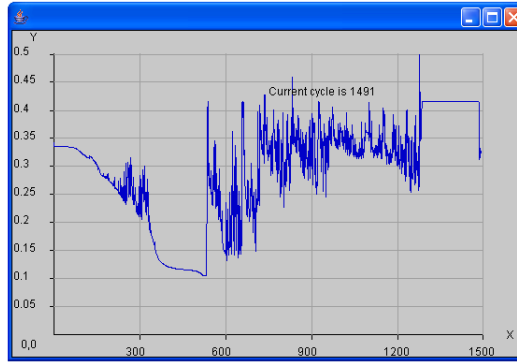

Test I1

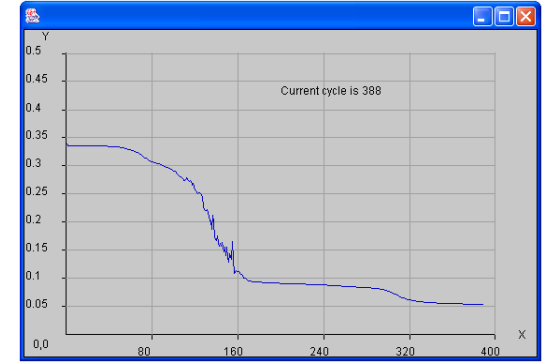

Test J1

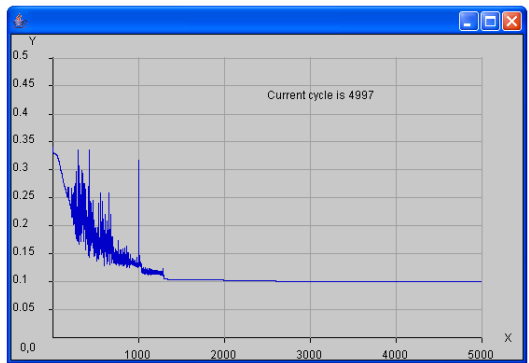

Test H3

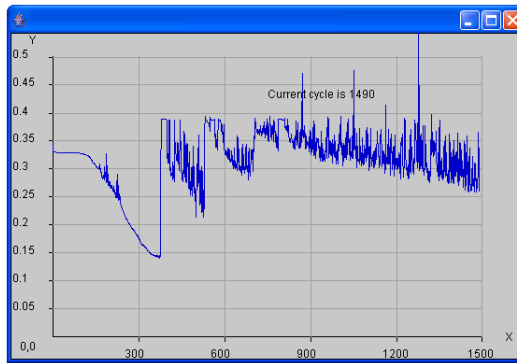

Test I2

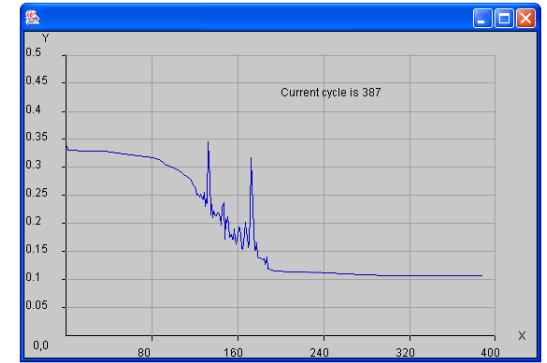

Test J2

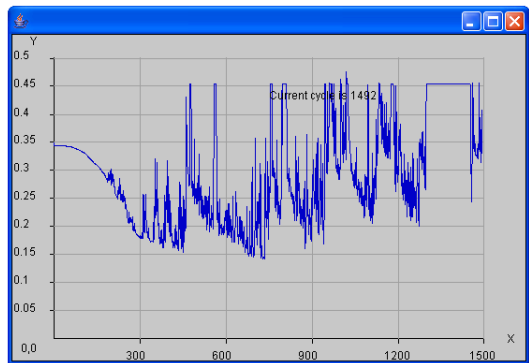

Test I



Test J

Appendix G - Altered Results Threshold

Desired	D2	Event	0.13	Desired	D6	Event	0.13	Desired	D8	Event	0.13	Desired	G1	Event	0.13	Desired	G3	Event	0.13	Desired	G5	Event	0.13	Desired	I	Event	0.13	Desired	I1	Event	0.13	Desired	I2	Event	0.13	
0	0		0	1	1		1	1	1		1	0	0		0	1	0.41	M	1	1	1		1	0	1	A	1	1	1	1	1	1	1	0	M	0
0	1	A	1	1	1		1	0	0		0	0	0		0	1	0.9		1	0	0		0	0	1	A	1	1	1	1	1	0	0	0	0	
1	1		1	0	1	A	1	0	0		0	1	1		1	0	0.44		1	0	1	A	1	1	1	1	1	1	0	1	A	1	0	0	0	
0	0		0	1	1		1	1	0	M	0	0	0		0	1	0.92		1	1	0	M	0	0	1	A	1	1	1	1	1	1	0	M	0	
0	0		0	0	0		0	1	0	M	0	0	0		0	0	0.03		0	1	1		1	0	1	A	1	0	1	A	1	1	0	M	0	
0	1	A	1	0	0		0	1	1		1	0	0		0	0	0		0	1	1		1	0	0		0	0	0	0	1	0	M	0		
0	1	A	1	1	0	M	0	0	0		0	0	1	A	1	1	0	M	0	0	0		1	0	0		1	1	0	M	1	0	0	0		
1	1		1	0	0		0	1	0	M	0	1	0	M	0	0	0.04		0	1	0	M	0	1	1		1	0	0	0	1	0	M	0		
0	1	A	1	1	1		1	0	0		0	0	1	A	1	1	0.99		1	0	0		0	0	0		1	1	1	1	0	0	0	0		
0	1	A	1	1	1		1	1	0	M	0	0	1	A	1	1	0.98		1	1	0	M	0	0	1	A	1	1	1	1	1	0	M	0		
1	0	M	0	0	0		1	1	0	M	1	1	0	M	0	0	0.02		0	1	1		1	1	1		1	0	0	0	1	0	M	0		
0	0		1	1	1		1	1	1		1	0	0		0	1	0.97		1	1	1		1	0	1	A	1	1	1	1	1	0	M	0		
0	0		0	1	0	M	0	1	1		1	0	0		0	1	0.02	M	0	1	1		1	0	0		1	1	0	M	0	1	0	M	0	
1	0	M	0	0	0		0	1	1		1	1	1		1	0	0.11		0	1	0	M	1	1	0	M	1	0	0	0	1	0	M	0		
0	0		0	0	0		0	1	0	M	0	0	0		0	0	0.03		0	1	0	M	0	0	0		0	0	0	0	1	0	M	0		
0	0		0	1	1		1	0	0		1	0	0		0	1	1		1	0	0		0	0	0		0	1	0	M	0	0	0	0		
0	0		0	0	0		0	1	1		1	0	0		0	0	0.49		1	1	0	M	0	0	0		0	0	0	0	0	1	1	1	1	
0	0		0	1	1		1	1	1		1	0	0		0	1	0.99		1	1	1		1	0	1	A	1	1	1	1	1	0	M	1		
1	0	M	0	1	0	M	0	0	1	A	1	1	0	M	0	1	0.01	M	0	0	1	A	1	1	1		1	1	1	1	0	0	0	1		
0	0		0	1	0	M	0	1	1		1	0	0		0	1	0	M	0	1	1		1	0	0		1	1	1	1	1	0	M	1		
1	0	M	0	0	0		0	1	1		1	1	1		1	0	0		0	1	1		1	1	1		1	0	0	0	1	0	M	0		
0	1	A	1	1	0	M	0	1	0	M	1	0	1	A	1	1	0.01	M	0	1	1		1	0	1	A	1	1	1	1	1	0	M	0		
0	1	A	1	0	0		0	0	0		0	0	1	A	1	0	0.42		1	0	0		0	0	0		0	0	1	A	1	0	0	0		
0	0		1	1	0	M	0	1	1		1	0	0		0	1	0.83		1	1	1		1	0	0		0	1	1	1	1	0	M	0		
0	0		0	1	1		1	0	0		0	0	0		0	1	0.61		1	0	0		0	0	0		1	1	1	1	0	0	0	0		
0	0		1	0	0		1	1	1		1	0	0		0	0	0.57	A	1	1	1		1	0	0		1	0	0	0	1	1	1	1		
0	0		0	0	0		0	1	1		1	0	0		1	0	0		0	1	0	M	0	0	0		1	0	1	A	1	1	1	1		
1	0	M	0	0	0		0	1	0	M	0	1	0	M	0	0	0		0	1	0	M	0	1	0	M	0	0	1	A	1	1	0	M	1	
Total	16		14	21	19		19	20		19	18	21	19		18	17		18	12		18	12	13		18	12	19	20		10	13		13			
Terror	2		2	9	9		12	14		3	3	9	10		12	13		5	6		5	6		5	6	12	13		3	6		6				

Appendix H – Theme Category Table

SUBJECT	BEHAVIOUR	MODIFIER
01	initialmovement	directyes
02	wilderness	directno
03	localbuilders	01
04	nationalbuilders	02
05	localelectricians	03
06	nationalelectricians	04
07	redsite	05
08	bluesite	06
09	greensite	07
10	yellowsite	08
11	checkpoint1	09
12	checkpoint2	10
13	checkpoint3	11
14	initialmobiledevice	12
15	nomdaction	noitems
16	incomingcall	1wiring
17	outgoingcall	1dynamite
18	vanweigh	1construction
19	reveal	1soil
20	nomeetingp01action	1fertiliser
21	meetp01	2wiring
	nomeetingp02action	2dynamite
	meetp02	2construction
	nomeetingp03action	2soil
	meetp03	2fertiliser
	nomeetingp04action	0
	meetp04	200
	nomeetingp05action	250
	meetp05	400
	nomeetingp06action	450
	meetp06	500
	nomeetingp07action	600
	meetp07	650
	nomeetingp08action	700
	meetp08	800
	nomeetingp09action	900
	meetp09	950
	nomeetingp10action	1000
	meetp10	1050
	nomeetingp11action	1200
	meetp11	1250
	nomeetingp12action	1400
	meetp12	1450
	randomcheck	1500
	nomeetingp13action	1600
	meetp13	1650
	nomeetingp14action	1700
	meetp14	1750
	nomeetingp15action	1800
	meetp15	1900
	nomeetingp16action	1950
	meetp16	2000

nomeetingp17action	2200
meetp17	2250
nomeetingp18action	5000
meetp18	1wiring1dynamite
nomeetingp19action	1wiring1construction
meetp19	1wiring1soil
nomeetingp20action	1wiring1fertiliser
meetp20	1dynamite1construction
nomeetingp21action	1dynamite1soil
meetp21	1dynamite1fertiliser
	1construction1soil
	1construction1fertiliser
	1soil1fertiliser
	walk
	13
	14
	15
	16
	17
	18
	19
	20
	21

Appendix I – Theme Data File

DATANAME	TIME	EVENT
th_game0_team3	0	:
th_game0_team3	0	07,initialmovement,directyes
th_game0_team3	0	07,initialmobiledevice
th_game0_team3	0	07,nomeetingp01action
th_game0_team3	0	07,nomeetingp02action
th_game0_team3	0	07,nomeetingp03action
th_game0_team3	0	07,nomeetingp04action
th_game0_team3	0	07,nomeetingp05action
th_game0_team3	0	07,nomeetingp08action
th_game0_team3	0	07,nomeetingp09action
th_game0_team3	0	07,nomeetingp12action
th_game0_team3	9	07,greensite,directyes
th_game0_team3	41	07,wilderness
th_game0_team3	78	07,meetp04
th_game0_team3	78	07,meetp05
th_game0_team3	91	07,nomeetingp04action
th_game0_team3	91	07,meetp03
th_game0_team3	91	07,nomeetingp05action
th_game0_team3	95	07,meetp12
th_game0_team3	112	07,nomeetingp03action
th_game0_team3	116	07,nomeetingp12action
th_game0_team3	188	07,meetp03
th_game0_team3	200	07,meetp12
th_game0_team3	201	07,outgoingcall,08
th_game0_team3	211	07,nomeetingp03action
th_game0_team3	218	07,nomeetingp12action
th_game0_team3	223	07,nomdaction
th_game0_team3	286	07,meetp09
th_game0_team3	403	07,nomeetingp09action
th_game0_team3	433	07,checkpoint3,directyes
th_game0_team3	433	07,reveal,walk
th_game0_team3	475	07,meetp09
th_game0_team3	481	07,incomingcall,08
th_game0_team3	487	07,nomdaction
th_game0_team3	487	07,nomeetingp09action
th_game0_team3	495	07,wilderness
th_game0_team3	548	07,nationalbuilders,directyes
th_game0_team3	569	07,meetp09
th_game0_team3	594	07,nomeetingp09action
th_game0_team3	685	07,wilderness
th_game0_team3	685	07,randomcheck
th_game0_team3	685	07,vanweigh,0
th_game0_team3	685	07,reveal,noitems
th_game0_team3	746	07,checkpoint3,directyes
th_game0_team3	746	07,reveal,walk
th_game0_team3	779	07,wilderness
th_game0_team3	853	07,yellowsite,directyes
th_game0_team3	855	07,wilderness
th_game0_team3	1029	07,localelectricians,directyes
th_game0_team3	1073	07,wilderness
th_game0_team3	1074	07,outgoingcall,09
th_game0_team3	1083	07,nomdaction

th_game0_team3	1090	07,checkpoint2,directyes
th_game0_team3	1090	07,vanweigh,800
th_game0_team3	1090	07,reveal,2wiring
th_game0_team3	1111	07,wilderness
th_game0_team3	1201	07,nationalelectricians,directyes
th_game0_team3	1211	07,meetp02
th_game0_team3	1211	07,meetp12
th_game0_team3	1233	07,nomeetingp02action
th_game0_team3	1233	07,nomeetingp12action
th_game0_team3	1243	07,wilderness
th_game0_team3	1305	07,meetp05
th_game0_team3	1323	07,nomeetingp05action
th_game0_team3	1324	07,nationalelectricians,directyes
th_game0_team3	1325	07,outgoingcall,09
th_game0_team3	1333	07,nomdaction
th_game0_team3	1350	07,wilderness
th_game0_team3	1371	07,checkpoint1,directyes
th_game0_team3	1371	07,vanweigh,1000
th_game0_team3	1371	07,reveal,2wiring
th_game0_team3	1391	07,wilderness
th_game0_team3	1418	07,bluesite,directyes
th_game0_team3	1425	07,wilderness
th_game0_team3	1425	07,randomcheck
th_game0_team3	1425	07,vanweigh,1000
th_game0_team3	1425	07,reveal,2wiring
th_game0_team3	1464	07,greensite,directyes
th_game0_team3	1485	07,wilderness
th_game0_team3	1763	07,greensite,directyes
th_game0_team3	1847	07,meetp09
th_game0_team3	2501	07,wilderness
th_game0_team3	2501	07,nomeetingp09action
th_game0_team3	2503	07,outgoingcall,08
th_game0_team3	2511	07,nomdaction
th_game0_team3	2512	07,greensite,directyes
th_game0_team3	2512	07,meetp09
th_game0_team3	2523	07,nomeetingp09action
th_game0_team3	2524	07,wilderness
th_game0_team3	2527	07,outgoingcall,02
th_game0_team3	2543	07,nomdaction
th_game0_team3	2573	07,bluesite,directyes
th_game0_team3	2584	07,wilderness
th_game0_team3	2586	07,bluesite,directyes
th_game0_team3	2594	07,wilderness
th_game0_team3	2608	07,checkpoint1,directyes
th_game0_team3	2616	07,wilderness
th_game0_team3	2637	07,nationalelectricians,directyes
th_game0_team3	2638	07,outgoingcall,08
th_game0_team3	2648	07,nomdaction
th_game0_team3	2737	07,wilderness
th_game0_team3	2737	07,randomcheck
th_game0_team3	2737	07,vanweigh,400
th_game0_team3	2737	07,reveal,2dynamite
th_game0_team3	2789	07,bluesite,directyes
th_game0_team3	2802	07,wilderness
th_game0_team3	2815	07,redsite,directyes
th_game0_team3	2815	07,meetp09
th_game0_team3	2829	07,wilderness

th_game0_team3	2910	07,nomeetingp09action
th_game0_team3	3005	07,greensite,directyes
th_game0_team3	3022	07,wilderness
th_game0_team3	3092	07,outgoingcall,02
th_game0_team3	3104	07,nomdaction
th_game0_team3	3107	07,meetp01
th_game0_team3	3114	07,meetp09
th_game0_team3	3134	07,nomeetingp09action
th_game0_team3	3139	07,nomeetingp01action
th_game0_team3	3206	07,yellowsite,directyes
th_game0_team3	3216	07,wilderness
th_game0_team3	3232	07,meetp08
th_game0_team3	3307	07,meetp01
th_game0_team3	3330	07,nomeetingp01action
th_game0_team3	3450	07,nomeetingp08action
th_game0_team3	3663	07,localelectricians,directyes
th_game0_team3	3663	07,randomcheck
th_game0_team3	3663	07,vanweigh,1000
th_game0_team3	3663	07,reveal,2wiring
th_game0_team3	3707	07,incomingcall,09
th_game0_team3	3712	07,nomdaction
th_game0_team3	3953	07,wilderness
th_game0_team3	4148	07,localelectricians,directyes
th_game0_team3	4148	07,meetp08
th_game0_team3	4229	07,nomeetingp08action
th_game0_team3	4264	07,wilderness
th_game0_team3	4270	07,checkpoint2,directyes
th_game0_team3	4270	07,vanweigh,1000
th_game0_team3	4270	07,reveal,2wiring
th_game0_team3	4281	07,wilderness
th_game0_team3	4320	07,greensite,directyes
th_game0_team3	4326	07,meetp09
th_game0_team3	4327	07,wilderness
th_game0_team3	4339	07,nomeetingp09action
th_game0_team3	4341	07,greensite,directyes
th_game0_team3	4360	07,meetp09
th_game0_team3	4371	07,nomeetingp09action
th_game0_team3	4377	07,wilderness
th_game0_team3	4399	07,meetp09
th_game0_team3	4447	07,meetp02
th_game0_team3	4550	07,meetp08
th_game0_team3	4577	07,nomeetingp02action
th_game0_team3	4664	07,nomeetingp08action
th_game0_team3	4706	07,nomeetingp09action
th_game0_team3	4726	07,greensite,directyes
th_game0_team3	4743	07,meetp09
th_game0_team3	4779	07,nomeetingp09action
th_game0_team3	4780	07,outgoingcall,08
th_game0_team3	4791	07,nomdaction
th_game0_team3	4800	07,meetp09
th_game0_team3	4819	07,wilderness
th_game0_team3	4819	07,nomeetingp09action
th_game0_team3	4950	07,checkpoint2,directyes
th_game0_team3	4976	07,meetp09
th_game0_team3	5000	07,meetp08
th_game0_team3	5033	07,nomeetingp09action
th_game0_team3	5038	07,nomeetingp08action

th_game0_team3	5041	07,wilderness
th_game0_team3	5065	07,localelectricians,directyes
th_game0_team3	5127	07,incomingcall,08
th_game0_team3	5137	07,nomdaction
th_game0_team3	5380	07,wilderness
th_game0_team3	5396	07,checkpoint2,directyes
th_game0_team3	5408	07,wilderness
th_game0_team3	5447	07,meetp08
th_game0_team3	5458	07,nomeetingp08action
th_game0_team3	0	08,initialmovement,directyes
th_game0_team3	0	08,initialmobiledevice
th_game0_team3	0	08,nomeetingp01action
th_game0_team3	0	08,nomeetingp02action
th_game0_team3	0	08,nomeetingp05action
th_game0_team3	0	08,nomeetingp07action
th_game0_team3	0	08,nomeetingp09action
th_game0_team3	16	08,greensite,directyes
th_game0_team3	32	08,wilderness
th_game0_team3	33	08,greensite,directyes
th_game0_team3	34	08,wilderness
th_game0_team3	35	08,greensite,directyes
th_game0_team3	44	08,wilderness
th_game0_team3	201	08,incomingcall,07
th_game0_team3	223	08,nomdaction
th_game0_team3	276	08,yellowsite,directyes
th_game0_team3	287	08,wilderness
th_game0_team3	480	08,checkpoint3,directyes
th_game0_team3	480	08,vanweigh,0
th_game0_team3	480	08,reveal,noitems
th_game0_team3	481	08,outgoingcall,07
th_game0_team3	487	08,nomdaction
th_game0_team3	491	08,wilderness
th_game0_team3	751	08,checkpoint3,directyes
th_game0_team3	753	08,wilderness
th_game0_team3	754	08,checkpoint3,directyes
th_game0_team3	756	08,wilderness
th_game0_team3	836	08,yellowsite,directyes
th_game0_team3	842	08,wilderness
th_game0_team3	855	08,yellowsite,directyes
th_game0_team3	859	08,wilderness
th_game0_team3	872	08,bluesite,directyes
th_game0_team3	894	08,wilderness
th_game0_team3	912	08,checkpoint2,directyes
th_game0_team3	912	08,reveal,walk
th_game0_team3	1023	08,wilderness
th_game0_team3	1040	08,localelectricians,directyes
th_game0_team3	1337	08,wilderness
th_game0_team3	1408	08,localelectricians,directyes
th_game0_team3	1437	08,wilderness
th_game0_team3	1518	08,localelectricians,directyes
th_game0_team3	1528	08,wilderness
th_game0_team3	1616	08,localelectricians,directyes
th_game0_team3	1660	08,wilderness
th_game0_team3	2481	08,localelectricians,directyes
th_game0_team3	2503	08,incomingcall,07
th_game0_team3	2511	08,nomdaction
th_game0_team3	2541	08,wilderness

th_game0_team3	2563	08,checkpoint2,directyes
th_game0_team3	2595	08,wilderness
th_game0_team3	2619	08,checkpoint1,directyes
th_game0_team3	2619	08,reveal,walk
th_game0_team3	2638	08,incomingcall,07
th_game0_team3	2641	08,wilderness
th_game0_team3	2648	08,nomdaction
th_game0_team3	2690	08,checkpoint2,directyes
th_game0_team3	2690	08,reveal,walk
th_game0_team3	2726	08,wilderness
th_game0_team3	2778	08,yellowsite,directyes
th_game0_team3	2781	08,wilderness
th_game0_team3	2849	08,checkpoint3,directyes
th_game0_team3	2849	08,reveal,walk
th_game0_team3	2862	08,wilderness
th_game0_team3	3016	08,greensite,directyes
th_game0_team3	3040	08,wilderness
th_game0_team3	3155	08,greensite,directyes
th_game0_team3	3163	08,meetp01
th_game0_team3	3179	08,nomeetingp01action
th_game0_team3	3183	08,wilderness
th_game0_team3	3213	08,yellowsite,directyes
th_game0_team3	3222	08,wilderness
th_game0_team3	3232	08,meetp07
th_game0_team3	3307	08,meetp01
th_game0_team3	3330	08,nomeetingp01action
th_game0_team3	3450	08,nomeetingp07action
th_game0_team3	3490	08,meetp05
th_game0_team3	3507	08,nomeetingp05action
th_game0_team3	3675	08,localelectricians,directyes
th_game0_team3	3702	08,wilderness
th_game0_team3	3750	08,localelectricians,directyes
th_game0_team3	4148	08,meetp07
th_game0_team3	4229	08,nomeetingp07action
th_game0_team3	4266	08,wilderness
th_game0_team3	4274	08,checkpoint2,directyes
th_game0_team3	4274	08,reveal,walk
th_game0_team3	4290	08,wilderness
th_game0_team3	4321	08,checkpoint1,directyes
th_game0_team3	4321	08,reveal,walk
th_game0_team3	4338	08,wilderness
th_game0_team3	4508	08,incomingcall,05
th_game0_team3	4531	08,nomdaction
th_game0_team3	4550	08,meetp02
th_game0_team3	4550	08,meetp07
th_game0_team3	4550	08,meetp09
th_game0_team3	4664	08,nomeetingp02action
th_game0_team3	4664	08,nomeetingp07action
th_game0_team3	4664	08,nomeetingp09action
th_game0_team3	4711	08,checkpoint1,directyes
th_game0_team3	4733	08,wilderness
th_game0_team3	4772	08,nationalelectricians,directyes
th_game0_team3	4780	08,incomingcall,07
th_game0_team3	4791	08,nomdaction
th_game0_team3	4816	08,wilderness
th_game0_team3	4968	08,checkpoint2,directyes
th_game0_team3	4968	08,reveal,walk

th_game0_team3	5000	08,meetp07
th_game0_team3	5000	08,meetp09
th_game0_team3	5033	08,nomeetingp09action
th_game0_team3	5038	08,nomeetingp07action
th_game0_team3	5051	08,wilderness
th_game0_team3	5081	08,checkpoint1,directyes
th_game0_team3	5081	08,vanweigh,0
th_game0_team3	5081	08,reveal,noitems
th_game0_team3	5098	08,wilderness
th_game0_team3	5124	08,nationalelectricians,directyes
th_game0_team3	5127	08,outgoingcall,07
th_game0_team3	5137	08,nomdaction
th_game0_team3	5162	08,wilderness
th_game0_team3	5211	08,checkpoint1,directyes
th_game0_team3	5216	08,wilderness
th_game0_team3	5216	08,randomcheck
th_game0_team3	5216	08,vanweigh,600
th_game0_team3	5216	08,reveal,2dynamite
th_game0_team3	5250	08,bluesite,directyes
th_game0_team3	5265	08,wilderness
th_game0_team3	5316	08,greensite,directyes
th_game0_team3	5366	08,wilderness
th_game0_team3	5447	08,meetp07
th_game0_team3	5458	08,nomeetingp07action
th_game0_team3	0	09,initialmovement,directyes
th_game0_team3	0	09,initialmobiledevice
th_game0_team3	0	09,nomeetingp01action
th_game0_team3	0	09,nomeetingp02action
th_game0_team3	0	09,nomeetingp03action
th_game0_team3	0	09,nomeetingp04action
th_game0_team3	0	09,nomeetingp05action
th_game0_team3	0	09,nomeetingp07action
th_game0_team3	0	09,nomeetingp08action
th_game0_team3	0	09,nomeetingp11action
th_game0_team3	12	09,greensite,directyes
th_game0_team3	40	09,wilderness
th_game0_team3	79	09,meetp04
th_game0_team3	95	09,meetp05
th_game0_team3	95	09,meetp11
th_game0_team3	110	09,nomeetingp04action
th_game0_team3	112	09,nomeetingp05action
th_game0_team3	119	09,nomeetingp11action
th_game0_team3	168	09,checkpoint2,directyes
th_game0_team3	168	09,reveal,walk
th_game0_team3	227	09,wilderness
th_game0_team3	255	09,yellowsite,directyes
th_game0_team3	272	09,wilderness
th_game0_team3	286	09,meetp07
th_game0_team3	403	09,nomeetingp07action
th_game0_team3	429	09,checkpoint3,directyes
th_game0_team3	429	09,reveal,walk
th_game0_team3	475	09,meetp07
th_game0_team3	487	09,nomeetingp07action
th_game0_team3	494	09,wilderness
th_game0_team3	547	09,nationalbuilders,directyes
th_game0_team3	569	09,meetp07
th_game0_team3	594	09,nomeetingp07action

th_game0_team3	597	09,wilderness
th_game0_team3	610	09,checkpoint3,directyes
th_game0_team3	646	09,wilderness
th_game0_team3	652	09,checkpoint3,directyes
th_game0_team3	663	09,wilderness
th_game0_team3	845	09,checkpoint2,directyes
th_game0_team3	845	09,reveal,walk
th_game0_team3	880	09,wilderness
th_game0_team3	1017	09,checkpoint1,directyes
th_game0_team3	1017	09,reveal,walk
th_game0_team3	1047	09,wilderness
th_game0_team3	1074	09,incomingcall,07
th_game0_team3	1083	09,nomdaction
th_game0_team3	1161	09,checkpoint2,directyes
th_game0_team3	1161	09,reveal,walk
th_game0_team3	1188	09,wilderness
th_game0_team3	1215	09,bluesite,directyes
th_game0_team3	1230	09,wilderness
th_game0_team3	1265	09,greensite,directyes
th_game0_team3	1325	09,incomingcall,07
th_game0_team3	1333	09,nomdaction
th_game0_team3	1341	09,wilderness
th_game0_team3	1352	09,yellowsite,directyes
th_game0_team3	1366	09,wilderness
th_game0_team3	1466	09,greensite,directyes
th_game0_team3	1847	09,meetp07
th_game0_team3	2501	09,nomeetingp07action
th_game0_team3	2512	09,meetp07
th_game0_team3	2523	09,nomeetingp07action
th_game0_team3	2526	09,wilderness
th_game0_team3	2566	09,checkpoint2,directyes
th_game0_team3	2588	09,wilderness
th_game0_team3	2615	09,checkpoint1,directyes
th_game0_team3	2615	09,reveal,walk
th_game0_team3	2636	09,wilderness
th_game0_team3	2693	09,bluesite,directyes
th_game0_team3	2708	09,wilderness
th_game0_team3	2723	09,redsite,directyes
th_game0_team3	2733	09,meetp01
th_game0_team3	2733	09,meetp03
th_game0_team3	2895	09,nomeetingp03action
th_game0_team3	3049	09,wilderness
th_game0_team3	3049	09,nomeetingp01action
th_game0_team3	3114	09,meetp01
th_game0_team3	3114	09,meetp07
th_game0_team3	3134	09,nomeetingp01action
th_game0_team3	3134	09,nomeetingp07action
th_game0_team3	3178	09,checkpoint2,directyes
th_game0_team3	3178	09,vanweigh,0
th_game0_team3	3178	09,reveal,noitems
th_game0_team3	3191	09,wilderness
th_game0_team3	3191	09,randomcheck
th_game0_team3	3191	09,vanweigh,0
th_game0_team3	3191	09,reveal,noitems
th_game0_team3	3277	09,localelectricians,directyes
th_game0_team3	3277	09,randomcheck
th_game0_team3	3277	09,vanweigh,0

th_game0_team3	3277	09,reveal,noitems
th_game0_team3	3313	09,wilderness
th_game0_team3	3670	09,localelectricians,directyes
th_game0_team3	3700	09,wilderness
th_game0_team3	3702	09,localelectricians,directyes
th_game0_team3	3707	09,outgoingcall,07
th_game0_team3	3712	09,nomdaction
th_game0_team3	3714	09,wilderness
th_game0_team3	3854	09,localelectricians,directyes
th_game0_team3	4258	09,wilderness
th_game0_team3	4267	09,checkpoint2,directyes
th_game0_team3	4275	09,wilderness
th_game0_team3	4324	09,greensite,directyes
th_game0_team3	4326	09,meetp07
th_game0_team3	4339	09,nomeetingp07action
th_game0_team3	4359	09,wilderness
th_game0_team3	4360	09,meetp07
th_game0_team3	4371	09,nomeetingp07action
th_game0_team3	4399	09,meetp07
th_game0_team3	4447	09,meetp02
th_game0_team3	4550	09,meetp08
th_game0_team3	4577	09,nomeetingp02action
th_game0_team3	4664	09,nomeetingp08action
th_game0_team3	4706	09,nomeetingp07action
th_game0_team3	4733	09,greensite,directyes
th_game0_team3	4743	09,meetp07
th_game0_team3	4779	09,nomeetingp07action
th_game0_team3	4800	09,meetp07
th_game0_team3	4819	09,nomeetingp07action
th_game0_team3	4827	09,wilderness
th_game0_team3	4832	09,yellowsite,directyes
th_game0_team3	4835	09,wilderness
th_game0_team3	4849	09,checkpoint2,directyes
th_game0_team3	4872	09,wilderness
th_game0_team3	4896	09,localelectricians,directyes
th_game0_team3	4945	09,wilderness
th_game0_team3	4965	09,checkpoint2,directyes
th_game0_team3	4976	09,meetp07
th_game0_team3	5000	09,meetp08
th_game0_team3	5033	09,nomeetingp07action
th_game0_team3	5033	09,nomeetingp08action
th_game0_team3	5038	09,wilderness
th_game0_team3	5081	09,localelectricians,directyes
th_game0_team3	5086	09,wilderness
th_game0_team3	5106	09,localelectricians,directyes
th_game0_team3	5384	09,wilderness
th_game0_team3	5395	09,checkpoint2,directyes
th_game0_team3	5405	09,wilderness
th_game0_team3	6000	&

8. References

Ambler, S.W. (2009) Introduction to Object-Orientation and the UML. [Internet], Available from: <<http://www.agiledata.org/essays/objectOrientation101.html>> [Accessed 26 January 2011].

Avery, L. (2007) **Mann-Whitney U Test** [Internet], Available from: <<http://elegans.swmed.edu/~leon/stats/utest.html>> [Accessed 27 October 2010].

Booch, G., Jacobson, I. & Rumbaugh, J. (2005) The Unified Modeling Language User Guide. Object Technology Series. 2nd Ed. Addison Wesley

Dixon, M. (2004) QSEE Superlite home. QSEE Technologies. [Internet], Available from: <www.leedsmet.ac.uk/qsee> [Accessed 26 October 2010].

The Eclipse Foundation, "Eclipse.org home" (2004) [Internet], Available from: <<http://www.eclipse.org/>> [Accessed 14 October 2010].

Ekman, P. (2001) Telling lies: Clues to deceit in the marketplace, marriage, and politics. New York, Norton

Ekman, P. & Yuille, J.C. (1989) Credibility Assessment (Dordrecht, Netherlands, Kluwer

Elman, J.L. (1991) Distributed representations, simple recurrent networks, and grammatical structure. **Machine Learning** volume 7, no. 2-3 195-224 [Internet], Available from: <<http://www.springerlink.com/content/x3u700q40767032g/>> [Accessed 28 October 2010].

Evertsz, R. et al (2009) Populating VBS2 with Realistic Virtual Actors. **Proceedings of the 18th Conference on Behavior Representation in Modeling and Simulation** p.1–8.

Ferreira, C. (2006) Gene Expression Programming: Mathematical Modeling by an Artificial Intelligence (Studies in Computational Intelligence). 2nd ed. Springer

Flanagan, D. (2002) Java In a Nutshell. 4th ed. O'Reilly Media

Haugeland, J. (1985) Artificial Intelligence: The Very Idea. Cambridge, Massachusetts, MIT Press

Heaton, J. (2010) Programming Neural Networks with Encog2 in Java. Heaton Research

Hocking, J.E. & Leathers, D.G. (1980) Nonverbal indicators of deception: A new theoretical perspective. **Routledge, Communication monographs**
Jonas, J. & Harper, J. (2006) Effective counterterrorism and the limited role of predictive data mining. **CATO Institute** [Internet], Available from:
<<http://www.cato.org/pubs/pas/pa584.pdf>> [Accessed 27 October 2010].

Joyce, J (2008) **Bayes' Theorem** [Internet], Fall 2008 Edition. Edward N. Zolta. Available from:
<<http://plato.stanford.edu/archives/fall2008/entries/bayes-theorem/>> [Accessed 21 December 2010].

Knapp M.L. & Comaden, M.E. (March 1979) Telling it like it isn't: A review of theory and research on deceptive communication. **Human Communication Research** Volume 5, no. 3 p.270-285 [Internet], Available from: <
<http://onlinelibrary.wiley.com/doi/10.1111/j.1468-2958.1979.tb00640.x/>> [Accessed 28 October 2010].

Levinson, N. (1946) The Wiener RMS (ROOT MEAN SQUARE) ERROR Criterion in Filter Design and Prediction. **Journal of Mathematics and Physics**.

Mann, H. B. & Whitney, D. R. (1947) On a test of whether one of two random variables is stochastically larger than the other. **Annals of Mathematical Statistics** Volume 18 March 1947, p.50–60.

Marappan, K., Nallaperumal, K., Kannan, S. and Bensujin, B. (2008) A Soft Computing Model to Counter Terrorism. **International Journal of Computer Science and Network Security**, Volume 8, May 2008, p.141.

Markman, A., Rachkovskij, D., Misuno, I. and Revunova, E. (2003) Analogical Reasoning Techniques in Intelligent Counterterrorism APNN. **International Journal ITA**, [Internet], Volume 10 (2) Available from:
<<http://www.foibg.com/ijita/vol10/ijita10-2.pdf#page=19>> [Accessed 27 November 2010].

Mitchell, T.M. (1997) **Machine Learning**, WCB-McGraw-Hill.

Neural Planner Software. (2010) **EasyNN-plus - Neural Network Software**. [Internet], Available from: <<http://www.easynn.com/>> [Accessed 26 October 2010].

Noldus Information Technology, (2004) Theme. **Noldus Information Technology** [Internet], Available from:
<<http://www.noldus.com/content/theme-0>> [Accessed 27 October 2010].

Oracle Corporation (2010) Oracle Spatial and Oracle Locator. [Internet], United States, Available from:
<<http://www.oracle.com/us/products/database/options/spatial>> [Accessed 26 October 2010].

- Petersen, U. (2004) Emdros: a text database engine for analyzed or annotated text. **Proceedings of the 20th international conference on Computational Linguistics** [internet], Available from: <<http://emdros.org/petersen-emdros-COLING-2004.pdf>> [Accessed 24 January 2011].
- Marrone, P. (2010) **An Object Oriented Neural Engine**. [Internet], SourceForge. Available from: <<http://www.jooneworld.com>> [Accessed 26 October 2010].
- Reece, G. (2000) Database Programming with JDBC and Java. 2nd Ed. Sebastopol, CA, USA, O'Reilly & Associates, Inc.
- Ripley, B.D. (2008) Pattern Recognition and Neural Networks. New York, Cambridge University Press
- Rudmin, F. (2006) Why Does the NSA Engage in Mass Surveillance of Americans When It's Statistically Impossible for Such Spying to Detect Terrorists? **Counterpunch**. [Internet], May, Available from: <<http://www.counterpunch.org/rudmin05242006.html>> [Accessed 30 October 2010].
- Scianta Intelligence (2001) **Data Mining** [Internet], California, Scianta Intelligence, LLC. Available from: <<http://scianta.com/technology/datamining.htm>> [Accessed 29 October 2010].
- Schneier, B. (2006) Why Data Mining Won't Stop Terror. **Wired** [Internet], Available from: <<http://www.wired.com/politics/security/commentary/securitymatters/2006/03/>> [Accessed 28 October 2010]
- Sexton, R.S. & Sikander, N.A. (2002) Data mining using a genetic algorithm-trained neural network. **Intelligent Systems in Accounting, Finance and Management**. [Internet], Volume 10 (Issue 4), December 2001, p.201-210. Available from: <<http://onlinelibrary.wiley.com/doi/10.1002/isaf.205/>> [Accessed 28 October 2010].
- Ware, B.S., Beverina, A., Gong, L. & Colder, B. (2002) **A Risk-Based Decision Support System for Antiterrorism**, [Internet], Available from: <www.dsbox.com/Documents/MSS_A_Risk-Based_Decision_Support_System_for_Antiterrorism.pdf> [Accessed 30 January 2009].
- Zuckerman, M., DePaulo, B. M., & Rosenthal, R. (1981) **Advances in experimental social psychology**. Volume 14. New York, Academic Press Inc.